

Dreame H12 Dual

Wet and Dry Vacuum User Manual

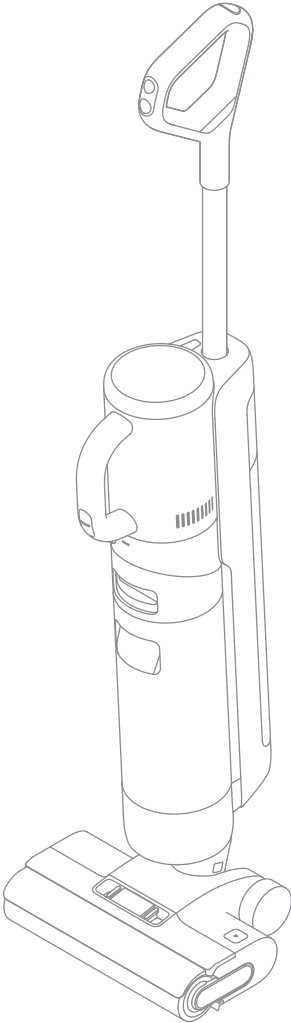

The illustrations in this manual are for reference only.
Please refer to the actual product.

dreame

THANK YOU

FOR PURCHASING THIS DREAME
WET AND DRY VACUUM.

Registration Quick Start

Welcome to register a Dreame account by scanning the QR code. You are available for the **User Manual** and **Special Offers**.



With it you are obtaining a high quality product that is engineered for optimal performance.

If you have any questions on the product, please contact us: aftersales@dreame.tech.

Contents

EN User Manual

001

Important Safety Instructions

- Please read this manual carefully before use and retain it for future reference.
- When using an electrical appliance, basic precautions should always be followed, including the following:
- READ ALL INSTRUCTIONS BEFORE USING (THIS APPLIANCE). Failure to follow the warnings and instructions may result in electric shock, fire and/or serious injury.

WARNING — To reduce the risk of fire, electric shock, or injury:

Usage Restrictions

- This appliance should not be used by children younger than 8 years old nor persons with physical, sensory, intellectual deficiencies, or limited experience or knowledge without the supervision of a parent or guardian to ensure safe operation and to avoid any risks. Cleaning and maintenance shall not be performed by children without supervision.
- Plastic film can be dangerous. To avoid the danger of suffocation, keep it away from children.
- Use indoors only, on non-carpeted floor surfaces such as vinyl, tile, sealed wood, etc. Be careful not to run over loose objects or the edges of area rugs. Stalling the brush may result in premature belt failure.
- Use only as described in this user guide. Use only manufacturer's recommended attachments.
- Do not expose the appliance to fire or excessive temperature. Exposure to fire or excessive temperature may cause an explosion.
- Do not use in extremely hot or cold environments (below 5°C /41° F or above 40° C/104° F). Please charge the appliance in temperature above 5°C /41° F and below 40°C /104° F).
- Do not immerse the appliance in liquid.
- Do not use to pick up flammable or combustible liquids, such as gasoline. Do not use in areas where flammable or combustible liquids may be present.
- Do not put any object into openings. Do not use the appliance when any opening is blocked. Keep free of dust, lint, hair, and anything that may inhibit air flow.
- Do not pick up toxic material (chlorine bleach, ammonia, drain cleaner, etc.). Do not pick up hard or sharp objects such as glass, nails, screws, coins, etc.
- Do not use the appliance in an enclosed space filled with vapor given off by oil-based paint, paint thinner, some moth-proofing substances, flammable dust, or other explosive or toxic vapour. Do not pick up anything that is burning or smoking, such as cigarettes, matches or hot ashes.
- Do not use the appliance without filters in place.
- Keep hair, loose clothing, fingers, and all parts of the body away from openings and moving parts of the appliance and its accessories.
- Keep ground cables away from the appliance when using it. A hazard may occur if the appliance runs over a supply cord.
- Use extra care when cleaning on stairs.

Maintenance and Storage

- Prevent unintentional starting. Ensure the switch is in the OFF-position before picking up or carrying the appliance. Carrying the appliance with your finger on the switch or turning on the appliance may result in an accident.
- Ensure that the appliance is placed on a horizontal surface. Do not use the appliance at the same position if the appliance is equipped with a brush roller and the handle is not completely upright. Do not store the appliance in a place where it may freeze.
- Switch off and unplug the appliance when not in use, before cleaning, maintaining or servicing it, and before connecting or disconnecting it with a moving brush.
- Do not use an appliance that is damaged or modified. A damaged or modified appliance may exhibit unpredictable behavior resulting in fire, explosion, or risk of injury.
- Do not modify or attempt to repair the appliance excepts as indicated in the instructions for use and care.
- Do not use the appliance with a damaged attachment (eg: charging base, supply cord etc.). If the appliance or attachment has been dropped, damaged, left outdoors, dropped into water, or is not working as it should, never attempt to operate it. Please have it repaired at an authorized service center.
- Have servicing performed by a qualified repair person using only identical replacement parts. This will ensure that the safety of the appliance is maintained.

Battery and Charging

- For the purpose of recharging the appliance, only use the charging base provided with this appliance. Use only with HCB3 charging base.
- Follow all charging instructions and do not charge the appliance outside of the temperature range specified in the battery as doing so increases the risk of fire.
- Charging base is equipped with drying function and only suitable for drying this appliance's brush.
- Keep the charging base cable away from heated surfaces. Do not handle the charging base plug or appliance with wet hands. To unplug, grasp the charging base plug, rather than the cable.
- Do not pull or carry charging base by cable, use cable as a handle, close door on cable, or pull cable around sharp edges or corners.
- This appliance contains batteries that can only be replaced by qualified technicians or after-sales service.
- The lithium-ion battery pack contains substances that are hazardous to the environment. Before disposing of the appliance, please first remove the battery pack, then discard, or recycle it in accordance with local laws and regulations of the country or region it is used in.
- The appliance must be disconnected from the power supply when removing the battery. Keep batteries out of the reach of children. Never put batteries in mouth. If swallowed, contact your physician or local poison control.
- Under abusive conditions, never contact the battery from which the liquid may be ejected. If contact accidentally occurs, rinse with water. If liquid contacts eyes, seek medical help immediately. Liquid ejected from the battery may cause irritation or burns.

 Detachable supply unit

 Read operator's manual

 Motorized cleaning head for water suction cleaning

We, Dreame Trading (Tianjin) Co., Ltd., hereby, declares that this equipment is in compliance with the applicable Directives and European Norms, and amendments. The full text of the EU declaration of conformity is available at the following internet address: <https://global.dreame.tech.com>

For detailed e-manual, please go to <https://global.dreame.tech.com/pages/user-manuals-and-faqs>

Packing List

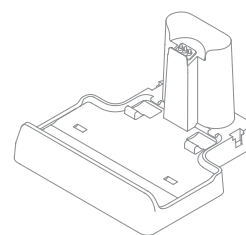

Charging Base



Storage Box



Dust Cup Assembly

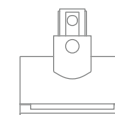

Motorized Mini-Brush

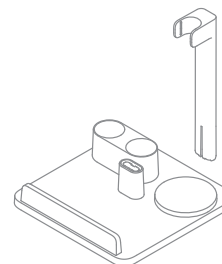

Accessory Storage Mount

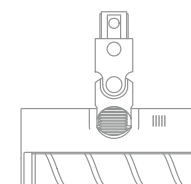

Soft Roller Brush



2-in-1 Crevice Nozzle

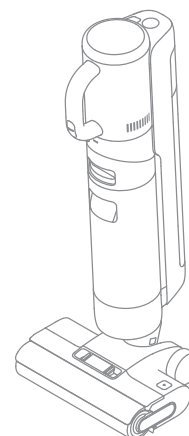

Main Body



Extension Rod



Handle



Replacement Filter



Cleaning Brush



Spare Brush Roller

Wet and Dry Vacuum Floor Washer

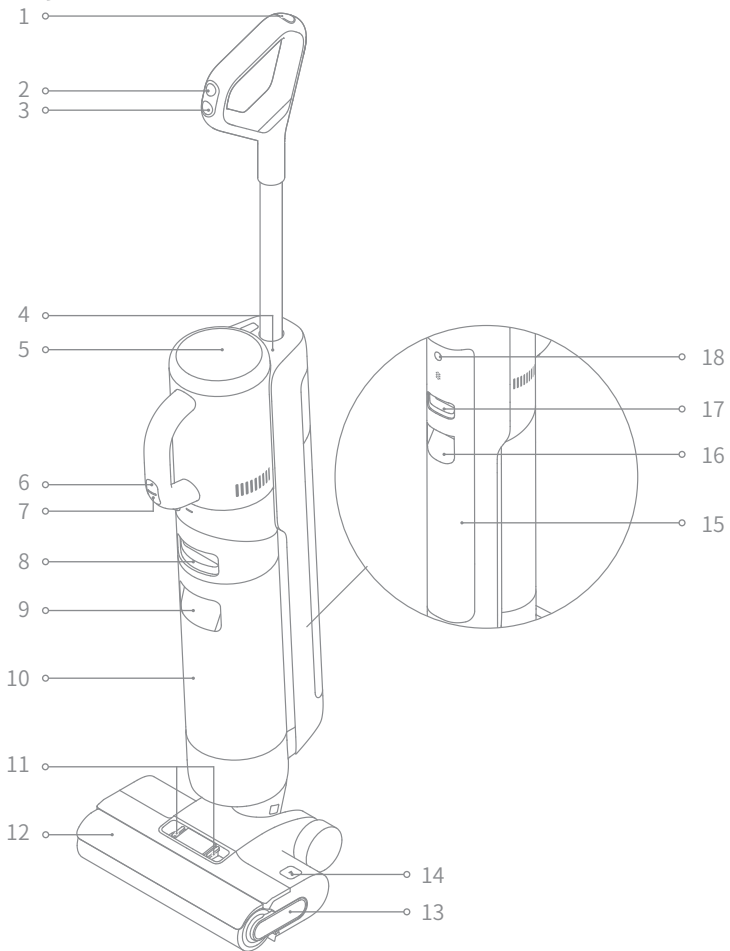

- | | | |
|--------------------------|---------------------------------------|---|
| 1 Self-Cleaning Button | 8 Used Water Tank Release Button | 15 Clean Water Tank |
| 2 Mode Switch | 9 Used Water Tank Handle | 16 Clean Water Tank Handle |
| 3 Power Switch | 10 Used Water Tank | 17 Clean Water Tank Release Button |
| 4 Handvac Release Button | 11 Brush Roller Cover Release Buttons | 18 Voice Prompt Button |
| 5 Display Screen | 12 Brush Roller Cover | <ul style="list-style-type: none"> Press briefly to activate the voice prompt or adjust the volume Press and hold for 3 seconds to access the language settings. Press to switch between languages. Press and hold to confirm the selection |
| 6 Handvac Mode Switch | 13 Brush Roller Handle | |
| 7 Handvac Power Switch | 14 Brush Roller Release Button | |

Charging Base

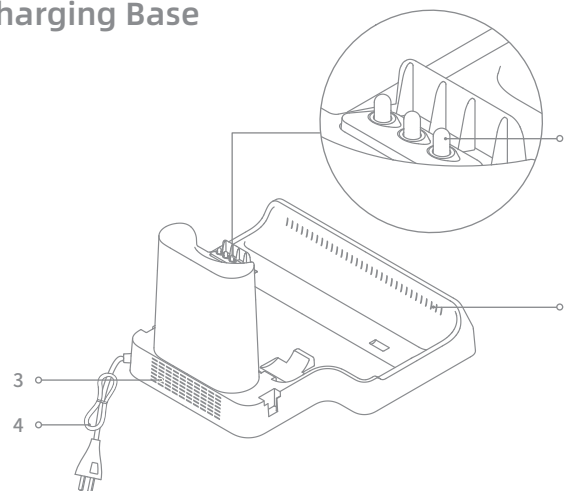

- 1 Charging Contacts
- 2 Air-Drying Inlet
- 3 Air-Drying Outlet
- 4 Power Cord

Display Screen

- Auto Mode
- Suction Mode
- Drying Mode
- Self-Cleaning
Press briefly to enable this function (battery level ≥ 15%)
Press and hold self-cleaning button for 3 seconds to activate drying mode.
- Standard Mode (Handvac)
- Turbo Mode (Handvac)
- Charging Indicator
Orange (charging): Battery level <20%
Green (charging): Battery level ≥ 20%
- Low Battery Indicator
Orange: Battery level <20%
Green: Battery level ≥ 20%

Error Messages

- Insufficient water in the Clean Water Tank
- Blocked tube
- Used Water Tank full
- Brush roller stuck

If the appliance is not working properly, the screen display will show an error message. Please refer to the troubleshooting table to find your solution.

Installation

Installing the Handle

Insert the end of the handle vertically into the port on the top of the appliance as indicated until you hear a click.

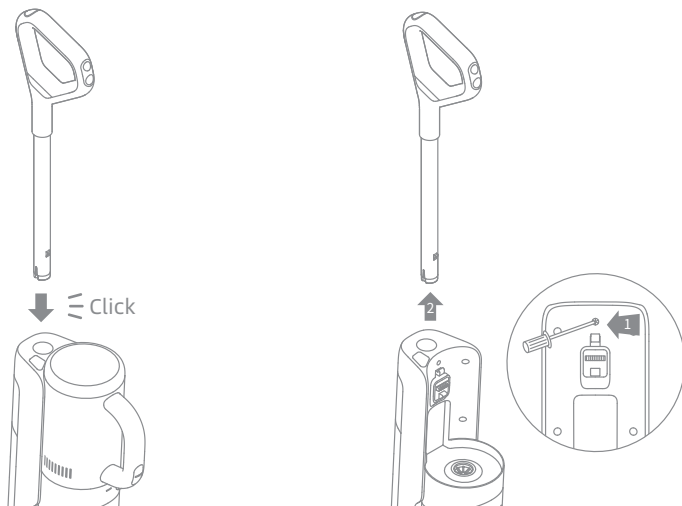

Note: To disassemble, extend a hard object into the hole on the back of the appliance to press contacts and pull the handle upwards at the same time.

Installing the Storage Box

Install the storage box onto the charging base.

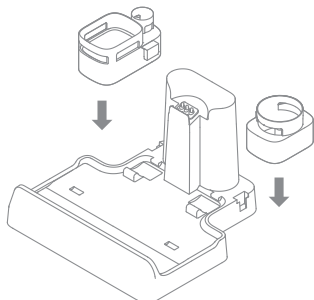

Installing the Accessory Storage Mount

Insert the support rod vertically into the storage mount until you hear a click.

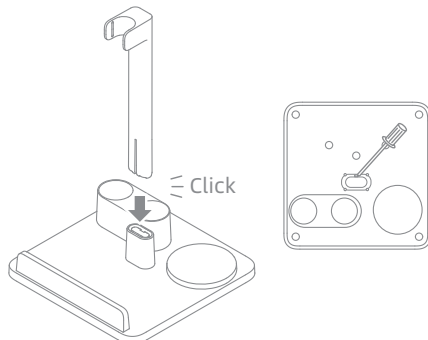

Note: To remove the support rod, extend a tool into the hole on the bottom of the mount to press contacts and pull the rod upwards at the same time.

Charging

1. Place the charging base against a wall on level ground and connect it to a power source. Fully charge the appliance before first use.
2. Place the appliance on the charging base, the ⚡ on the screen will light up to indicate the charging status. When charging, the number on the display screen represents the current battery level as a percentage. When the number reaches 100, the battery is fully charged and the ⚡ will turn off.

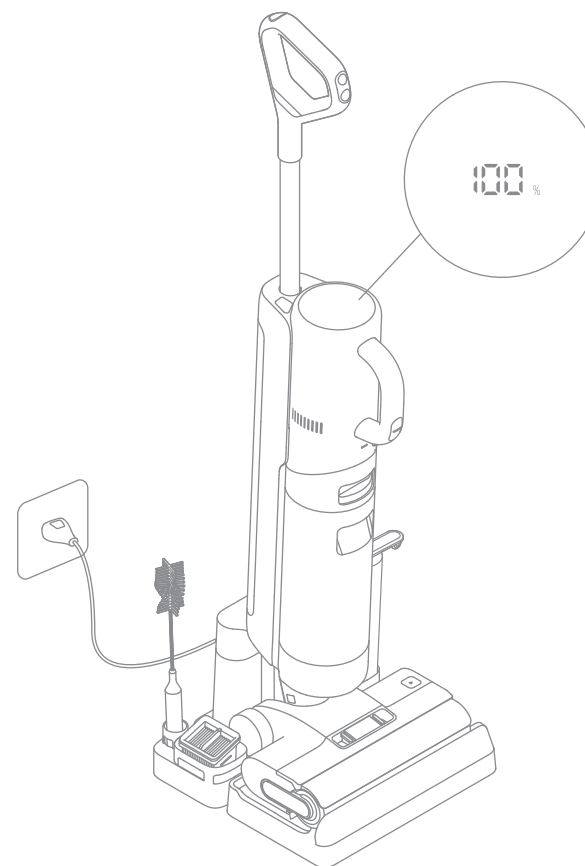

Note:

- If no operation is performed within 10 minutes, the appliance will enter the sleep mode.
- To extend the battery life time, the battery keeps cooling down for about one hour automatically after you have used the appliance for a long time.

How to Use

Switching Modes

The appliance is powered on in Auto mode by default, you can switch to Suction mode as needed.



Auto Mode

While washing the floor, the appliance can adjust its suction power according to different situations.



Suction Mode

If Suction mode is selected, the appliance will vacuum water only and the brush roller will not be dampened. No water is coming out of the Clean Water Tank.



Standard Mode (Handvac)

When the appliance converts to a handheld vacuum, it is powered on by default in Standard mode.



Turbo Mode (Handvac)

Press the handvac mode switch to select the Turbo mode.

Using as a Floor Washer

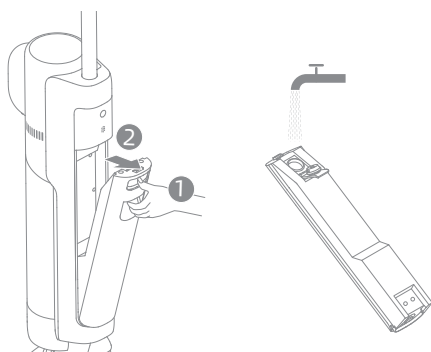

1. Fill the Clean Water Tank: Press the Clean Water Tank release button to remove the tank. Open the tank cover and fill the tank with clean water. Re-install the Clean Water Tank and ensure it clicks into place.



Note:

- For better cleaning performance, it is recommended to add 10ml detergent with the bottle cap into the full Clean Water Tank, then shake gently and evenly for use.
- Do not add any liquids other than the officially-approved cleaner.

How to Use

2. Start cleaning: Gently step on the brush cover and recline the appliance backwards. Press the power switch  to start operating, press the mode switch  to switch between the Auto mode and the Suction mode according to your needs.

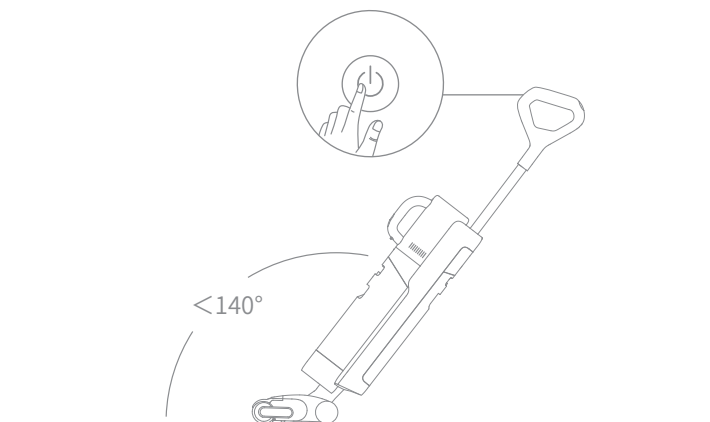

Note:

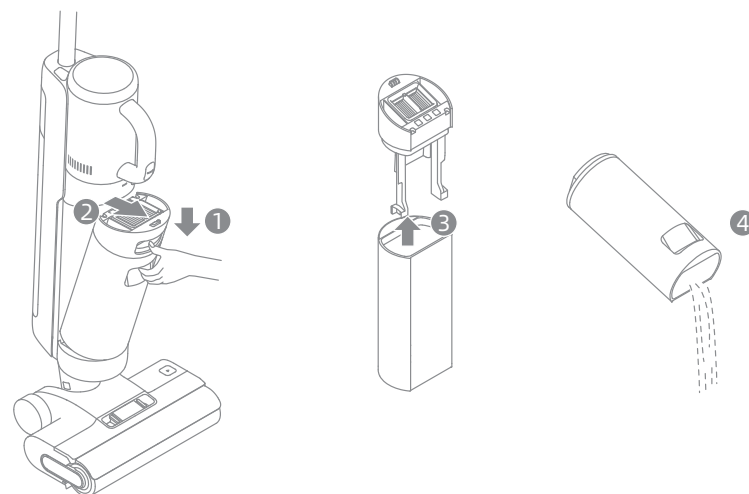

- Do not vacuum any foamy liquids.
- If the appliance is in the upright position while working, the current task will be suspended.
- The appliance is suitable for cleaning floors, marble, tiles and other hard surfaces.
- Do not recline the appliance backwards more than 140° to prevent the appliance from leaking water.
- When the appliance is in operation, do not lift it off the ground, move it, tilt it or lay it flat. Doing so may cause the used water to flow into the motor.

3. Empty the Used Water Tank: Press the Used Water Tank release button to take out the tank. Remove the tank cover and pour out the used water. Close the tank cover and re-install the tank before use.



How to Use

Self-cleaning Mode

1. Place the appliance back onto the base while you finish cleaning.
2. Briefly press the self-cleaning button  on the top of the handle to start/stop self-cleaning.
3. Empty the Used Water Tank while self-cleaning is completed. Then the appliance starts drying mode. Press the button  to exit drying mode.

Note: The self-cleaning mode can be enabled only when the appliance is being charged and the battery level is more than 15%.

Drying Mode

1. Press and hold the self-cleaning button  for 3 seconds to activate drying mode.
2. The appliance will be charged once drying is completed.

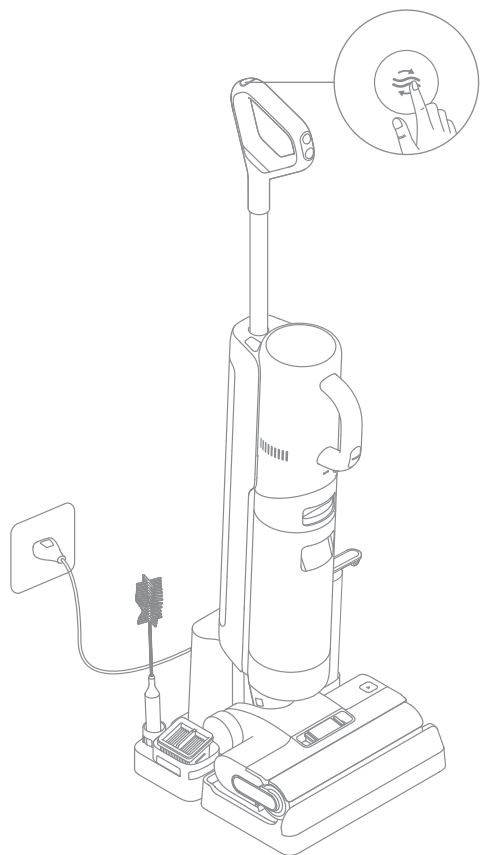

Note:

- Clean the charging base if there are any stains left on the base after self-cleaning is complete.
- If cleaning the brush roller manually, please air dry thoroughly or dry it by using drying mode several times.



How to Use

Using as a Handheld Vacuum

1. Press the handvac release button to remove the handvac.
2. Install the dust cup assembly and other attachments as shown in the diagram until you hear a click.
3. Briefly press the handvac Power Switch  to start operating. Briefly press the handvac mode switch  to switch between Standard mode and Turbo mode according to your needs.

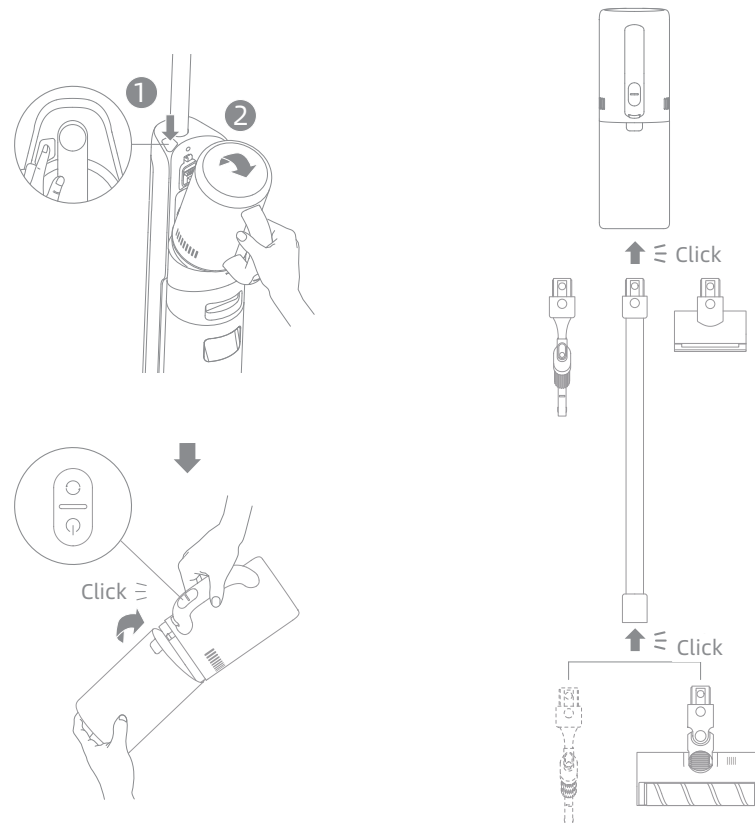

Note: Motorized mini-brush should not be used with the extension rod.

Using Different Attachments

Combination Tool: For cleaning corners, stairs, sofas, coffee tables and other narrow spaces.

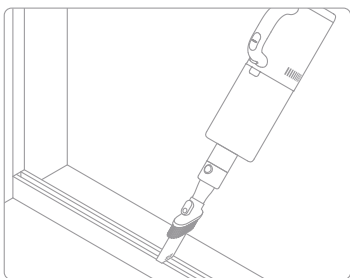

Soft Roller Brush: Suitable for cleaning hard floors such as

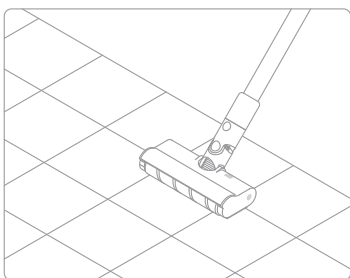

Accessory Storage Mount: Store the dust cup assembly, soft roller brush, combination tool, and motorized mini-brush on the mount as shown in the diagram.

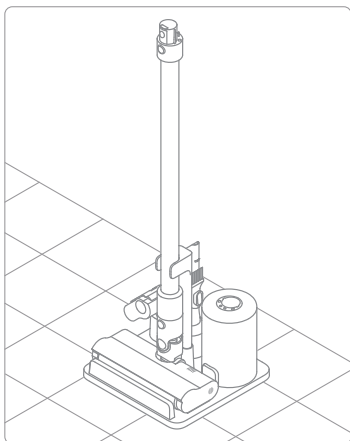

CAUTION! To avoid the damage of appliance, do not put the handheld vacuum on the accessory storage mount.

Motorized Mini-Brush: For vacuuming dirt, pet hair, and other stubborn debris from sofas, bedding, and other fabric surfaces.

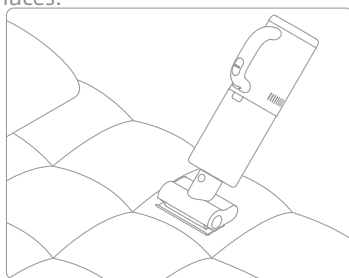

Storage Box: Store the cleaning brush, the filter, and the brush roller on the storage box as shown in the diagram.

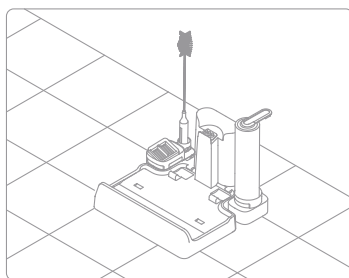

Tips:

- Turn off the appliance before performing care and/or maintenance. Do not touch the Power Switch.
- Replace parts if needed. The parts must be replaced by those available from the manufacturer or its service agent.
- If the appliance is not used for an extended period, fully charge it, unplug the power adapter, and store the appliance in a cool, low-humidity environment away from direct sunlight. To avoid over-discharge of the battery, charge the appliance at least once every 3 months.

Cleaning the Used Water Tank and the Filter

Note:

- Cleaning the Used Water Tank after each use is recommended.
- Replacing the filter every 3 to 6 months is recommended.

1. Press the Used Water Tank release button and take out the Used Water Tank.

2. Take out the filter from the Used Water Tank cover. Remove the tank cover and pour out the wastewater.

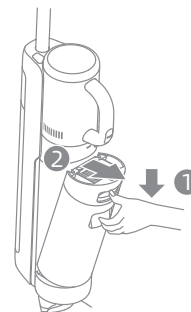

3. Rinse the Used Water Tank and the tank cover with water, the provided cleaning brush can be used to clean the inner wall of the tank.

4. Close the Used Water Tank cover, re-install the Used Water Tank and ensure the tank clicks into place.

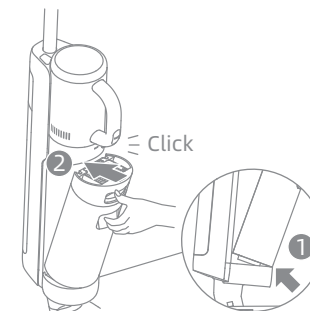
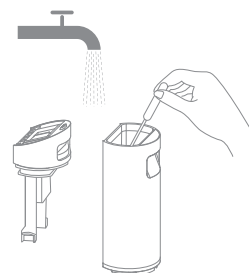

Note: When the filter is dirty and needs washing, rinse it with water. It must be completely dry before use.

Care and Maintenance

Cleaning the Tube and the Dirt Sensor

Remove the Used Water Tank, wipe the tube and the dirt sensor with a wet cloth before use.

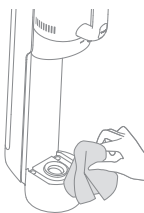

Cleaning the Dust Cup Assembly

Note:

- Cleaning the dust cup after each use or after the amount of dust in the cup reaches the MAX line is recommended.
- Replacing the filter every 3 to 6 months is recommended.

1. Press the dust cup release button and remove the cup.

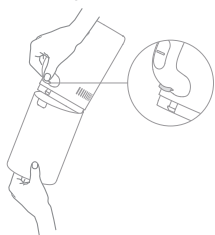

2. Take out the filter and the cyclone assembly from the dust cup, then empty the cup.

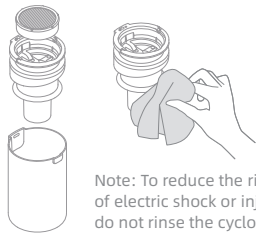

Note: To reduce the risk of electric shock or injury, do not rinse the cyclone assembly with water.

3. Tap the filter gently or clean it with the cleaning brush. Rinse the filter and the dust cup with water.



4. Dry the filter and the dust cup completely before use.

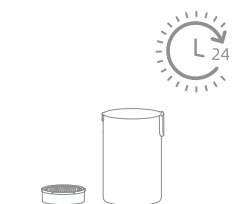

Cleaning the Brush Assembly

Note:

- Clean as needed. Alternating use of the two provided brush rollers is recommended.
- Replacing the brush roller every 3 to 6 months is recommended.

1. First, press the brush roller cover release buttons inwards on both sides to remove the brush roller cover. Next, press the brush roller release button and the handle of the brush roller will pop out. Pull the handle to take out the brush roller.

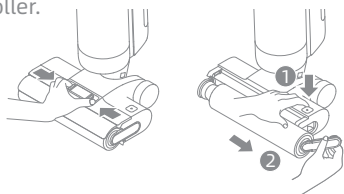

2. Clean out any hair and debris tangled on the brush roller with the provided cleaning brush. Rinse the brush roller with clean water and dry it completely.

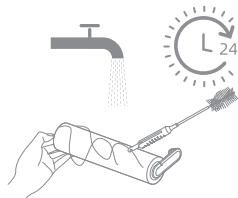

Care and Maintenance

3. Wipe the suction inlet with a dry cloth or wet tissue. Do not rinse the brush assembly with water.

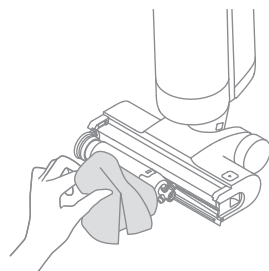

4. After cleaning the brush roller, re-install the brush roller and the brush roller cover. You will hear a click to indicate that they are installed in place.

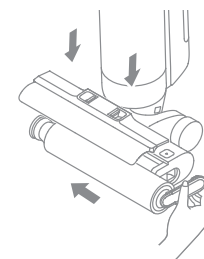

Cleaning the Soft Roller Brush

1. As shown in the picture, press the brush roller release button to remove the roller from the slot.

2. When it is dirty, rinse the brush roller with clean water. Stand the brush roller upright until it is fully dry.

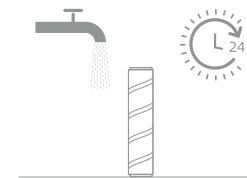
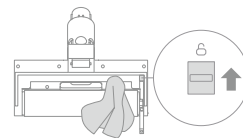

Cleaning the Motorized Mini-Brush

1. Use a coin as illustrated to rotate the lock counterclockwise, and remove the brush roller until you hear a click.



2. When it is dirty, rinse the brush roller with clean water. Stand the brush roller upright until it is fully dry.







If an error occurs, the appliance will stop working. Please refer to the following table for troubleshooting. If the problem persists, please contact the customer service.

Error	Possible Cause	Solution
The appliance does not work.	The appliance is out of battery or its battery level is low.	Fully charge its battery before use.
	The appliance is in the upright position.	Recline the appliance backwards.
	The appliance is overheating due to blockage and the high-temperature cut-off has activated.	Clear the blockage and wait until the temperature returns normal.
	The Used Water Tank is full.	Empty the Used Water Tank.
	The handle or Used Water Tank is not installed in place.	Ensure the handle or Used Water Tank are all properly in place.
The appliance charges slowly.	The temperature of the battery is too low or too high.	Wait until the battery's temperature returns normal.
The suction power of the appliance is weak.	The filter is clogged.	Clean the Used Water Tank and the filter that is in the dust cup.
	There are some foreign objects in the tube and the suction inlet or the tube and the suction inlet are blocked.	Clean the tube and the suction inlet.
The motor is making a strange noise.	There is too much dirty water in the Used Water Tank.	Empty the Used Water Tank.
	The suction inlet is blocked.	Clear any blockage in the suction inlet.
The display screen does not light up while charging.	The charging base plug is not inserted into the electrical outlet properly.	Make sure the charging base plug is inserted in place.
	The appliance is not placed onto the charging base properly.	Make sure the appliance is placed onto the charging base properly.
No water is coming out of the appliance.	The Clean Water Tank is not properly installed in place, or the water in the Clean Water Tank is insufficient.	Re-install or fill the Clean Water Tank.
	It takes 30 seconds to dampen the brush roller.	Turn on the appliance and check again in 30 seconds.

The vent leaks water.	A collision or a sharp pull causes water to enter the motor.	Move the appliance gently back and forth while it is turned on.
	The filter is not completely dry after being cleaned.	Dry the filter completely before use.
Self-cleaning fails.	The brush roller may be jammed by large debris.	Open the brush roller cover to check and clean the brush roller.
	The appliance is not being charged.	Make sure the appliance is being charged before enabling the self-cleaning function.
	Self-cleaning cannot be enabled if the battery level is lower than 15%.	The self-cleaning function can only be enabled when the appliance is being charged and the battery level is more than 15%.
	The Used Water Tank is not installed in place, or the Used Water Tank is full.	Re-install or empty the Used Water Tank.
	The Clean Water Tank is not installed in place, or the water in the Clean Water Tank is insufficient.	Fill or re-install the Clean Water Tank.
Poor drying performance.	The air outlet and air inlet of the charging base may be blocked.	Check and clear the blockage of air outlet and air inlet.

Error Prompts and Solutions

If the appliance is not working properly, the screen display will show an error message. Please refer to the troubleshooting table to find your solution.

Error Icon	Possible Cause	Solution
	Insufficient water in Clean Water Tank	Fill the Clean Water Tank.
	Used Water Tank not installed	Install the Used Water Tank.
	Used Water Tank full	Empty the Used Water Tank.
	Brush roller stuck	Clean the brush roller with the provided cleaning brush.
	Blocked tube	Check whether the filter is clogged. Alternatively, clean the tube and the dirt sensor.

Troubleshooting Code	Possible Cause	Solution
E1-E7	Error	Restart the appliance for troubleshooting. If the problem persists, please contact customer service.
H1-H6		
H7	Battery overheating	Wait until the battery's temperature returns normal.

Specifications

Wet and Dry Vacuum Floor Washer			
Model	HHV4	Rated Power	300 W
Rated Voltage	21.6 V ===	Charging Voltage	27 V ===
Used Water Tank Capacity	700 mL	Clean Water Tank Capacity	900 mL
Charging Time	Approx. 4.5 hours	Drying Time	Approx. 30 mins
Charging Base			
Model	HCB3		
Input	100-240 V~ 50/60 Hz 0.8 A Max	Output	27 V === 1.6 A

Battery Disposal and Removal

The built-in lithium-ion battery contains substances that are hazardous to the environment. Before disposing of the battery, make sure the battery is removed by qualified technicians and discarded at an appropriate recycling facility.

- the battery must be removed from the appliance before it is scrapped;
- the appliance must be disconnected from the supply mains when removing the battery;
- the battery is to be disposed of safely.

Removal Guide

1. Re move the display screen by rotating it with a tool.
2. Remove the screws on the battery cover in turn and then pry open the cover with proper tools.
3. Unplug the terminals between the battery and PCB board to remove the battery.

CAUTION:

- Before removing the battery, disconnect the power and run out the battery as much as possible.
- Unneeded batteries should be discarded at an appropriate recycling facility.
- Do not expose to high temperature environment to avoid risks of explosion.
- Under abusive conditions, liquid may be ejected from the battery. If contact occurs, flush with water and seek medical help.

WEEE Information



All products bearing this symbol are waste electrical and electronic equipment (WEEE as in directive 2012/19/EU) which should not be mixed with unsorted household waste. Instead, you should protect human health and the environment by handing over your waste equipment to a designated collection point for the recycling of waste electrical and electronic equipment, appointed by the government or local authorities. Correct disposal and recycling will help prevent potential negative consequences to the environment and human health. Please contact the installer or local authorities for more information about the location as well as terms and conditions of such collection points.

- The word "dreame" is the abbreviation of Dreame Technology Co., Ltd. and its subsidiaries in China. It is the transliteration of the company's Chinese name "追觅", which means striving for excellence in every endeavor and reflects the company's vision of continuous pursuit, exploration and search in technology.



Website: <https://global.dreametech.com>
Manufactured by: Dreame Trading (Tianjin) Co., Ltd.
Made in China

12/2022
HHV4-EU-S00