

Dreame Bot Z10 Pro

Auto-Empty Robot Vacuum and Mop
User Manual

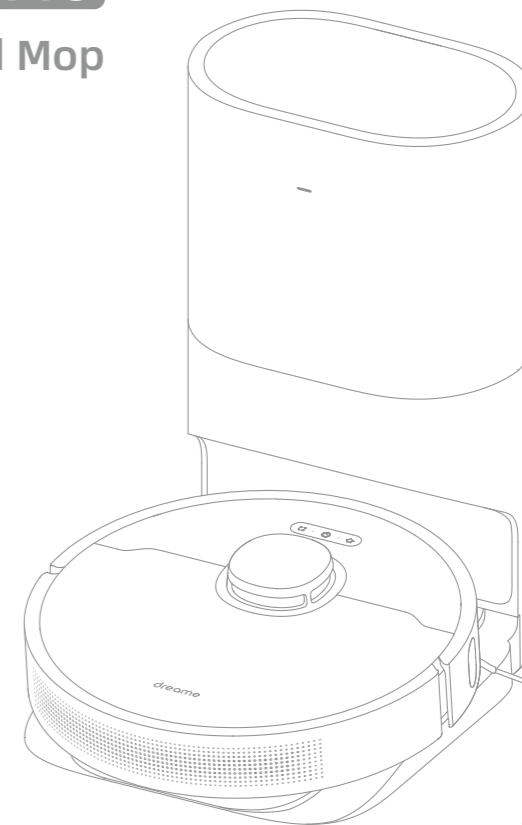

For more information, please visit www.dreame-technology.com
Manufactured by: Dreame Trading (Tianjin) Co., Ltd.
Made in China

RLSD5-EU-R00

Read this manual carefully before use and keep it for future reference.

dreame

Content

EN	User Manual	1
DE	Benutzerhandbuch	22
FR	Manuel d'utilisation	44
IT	Manuale utente	66
ES	Manual de usuario	88
RU	Руководство пользователя	110
PL	Instrukcja obsługi	133
HE	מדריך למשתמש	155
SA	مدخستلا ليلد	175

Safety Information

Usage Restrictions This product can be used by children aged 8 years and above and persons with physical, sensory, intellectual deficiencies, or limited experience or knowledge under the supervision of a parent or guardian to ensure safe operation and to avoid any risks. Cleaning and maintenance shall not be done by children without supervision.

Children shall not play with this product. Ensure children and pets are kept at a safe distance from the robot while it is operating.

This product is for floor cleaning in a home environment only. Do not use it outdoors, on non-floor surfaces, or in a commercial or industrial setting.

Do not use the robot in an area suspended above ground level without a protective barrier.

Do not use the robot at an ambient temperature above 40° C or below 0° C or on a floor with liquids or sticky substances.

Pick up any cables from the floor before using the robot to prevent it from dragging them while cleaning.

Remove fragile or small items from the floor to prevent the robot from bumping into and damaging them.

Keep hair, fingers, and other body parts away from the suction opening of the robot.

Keep the brush cleaning tool out of reach of children.

Usage Restrictions Do not place children, pets, or any item on top of the robot regardless of whether it is stationary or moving.

Do not use the robot to clean any burning objects.

Do not vacuum hard or sharp objects.

Make sure the robot is turned off and the auto-empty base is unplugged before cleaning or performing maintenance.

Do not wipe any part of the product using a wet cloth or liquids.

Please use this product in accordance with the instructions in the User Manual. Users are responsible for any loss or damage that arise from improper use of this product.

Batteries and Charging Do not use any third-party battery or auto-empty base. Use only with RCS2 supply unit.

Do not attempt to disassemble, repair, or modify the battery or auto-empty base on your own.

Do not place the auto-empty base near a heat source.

Do not use a wet cloth or wet hands to wipe or clean the base's charging contacts.

Batteries and Charging Do not improperly dispose of old batteries. Unneeded batteries should be discarded at an appropriate recycling facility.

If the power cord becomes damaged or broken, stop using it immediately and contact after-sales service.

Make sure the robot is turned off when being transported and kept in its original packaging if possible.

If the robot will not be used for an extended period, fully charge it, then turn it off and store in a cool, dry place. Recharge the robot at least once every 3 months to avoid over-discharging the battery.

This product contains batteries that can only be replaced by qualified technicians or after-sales service.

Hereby, Dreame Trading (Tianjin) Co., Ltd. declares that the radio equipment type RLSD5 is in compliance with Directive 2014/53/EU. The full text of the EU declaration of conformity is available at the following internet address: www.dreame-technology.com

Accessories



Cleaning Tool



Side Brush

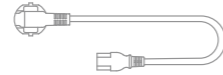

Power Cord

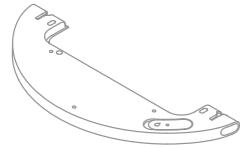

Water Tank



Mop Pad



Dust Collection Bag

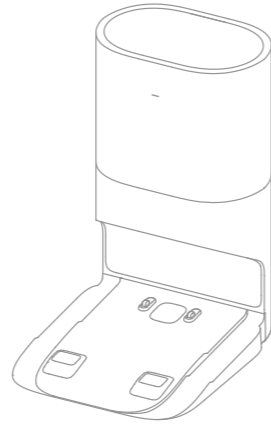

Auto-Empty Base

Note: The illustrations in this manual are for reference only. Please refer to the actual product.

Robot

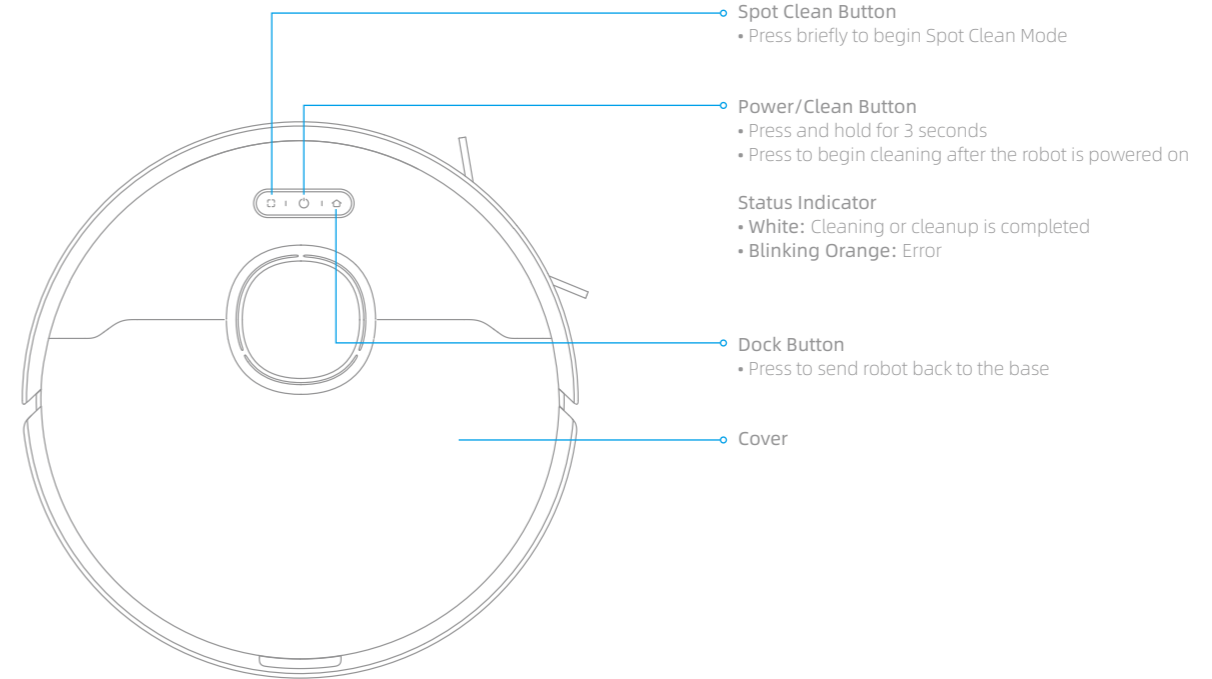

Robot

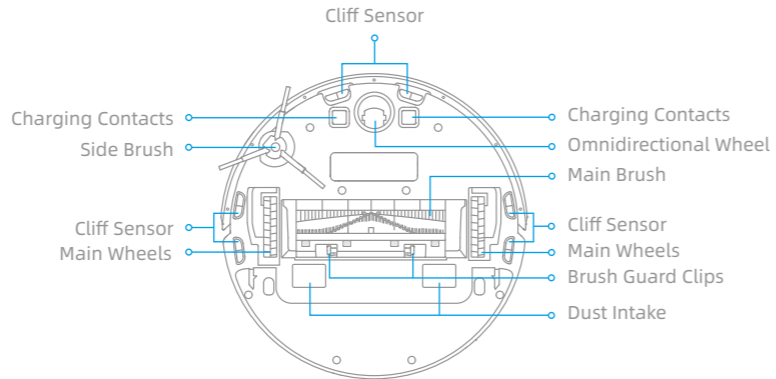
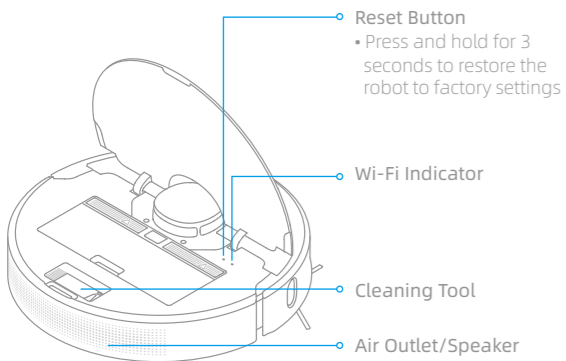

Robot Sensors

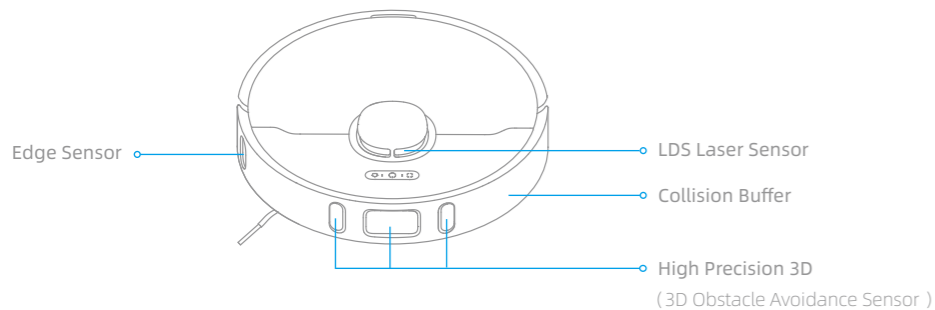

Auto-Empty Base

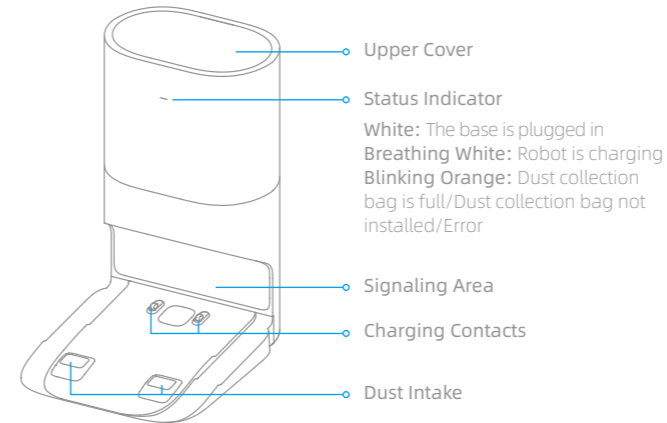

Auto-Empty Base (Back)

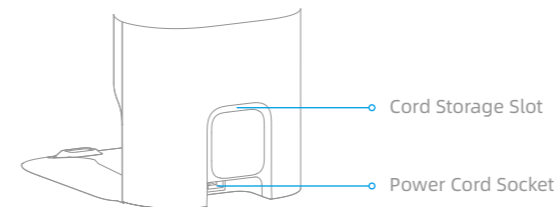

Auto-Empty Base (Open the upper cover)

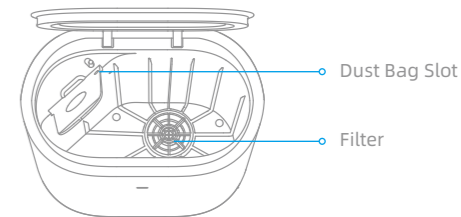

Auto-Empty Base (Bottom)

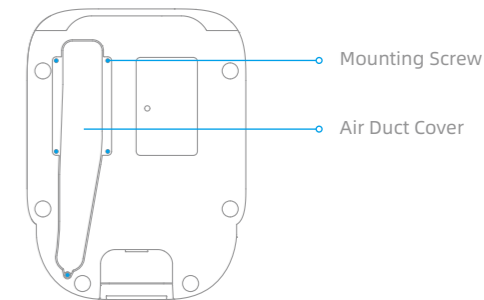

Dust Bin

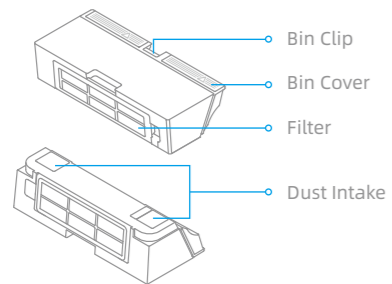

Dust Collection Bag

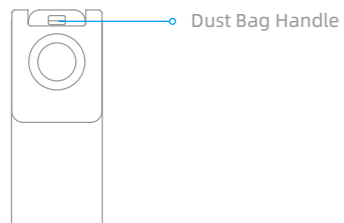

Note: Due to the factory setting, a new dust collection bag has been installed inside already.

Mopping Module

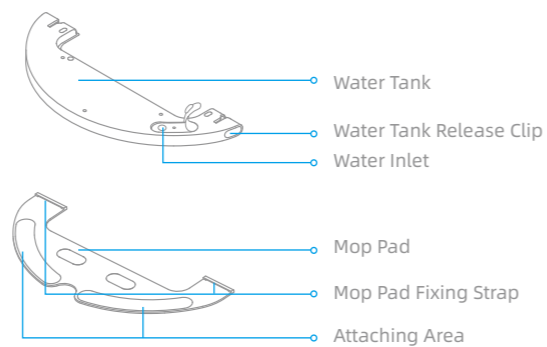

Clearing Home Environment



To improve the working efficiency of your robot, put away any loose cords , rags, slippers, toys, etc.

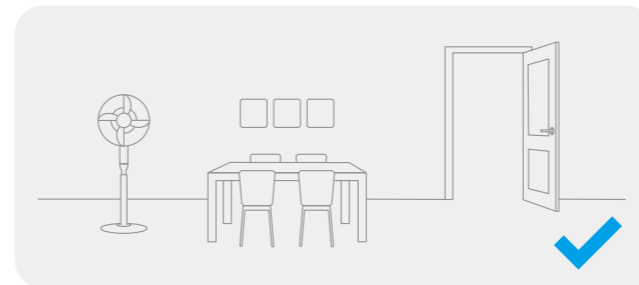

Open the door of the room to be cleaned, and put the furniture in its proper place to make more space.

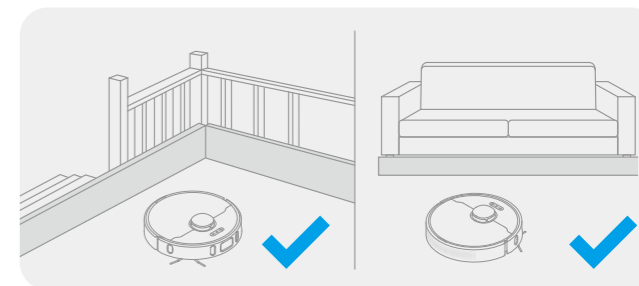

Before cleaning, place a physical barrier at the edge of the stairs and sofa to ensure safe and smooth operation of the robot.

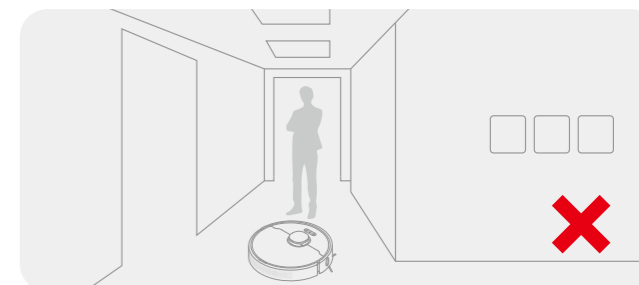

To prevent the robot from not recognizing the area that needs to be cleaned, do not stand in the front of the robot, threshold, hallway, or narrow places.

Preparation Before Use

1. Remove the protective matter

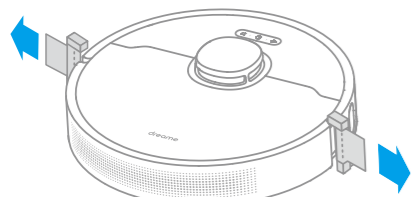

2. Install the side brush

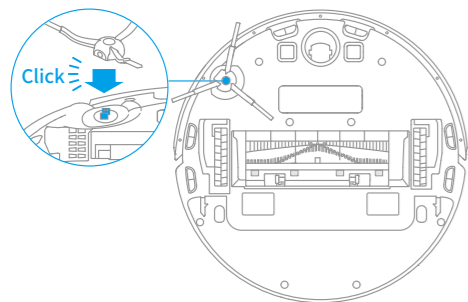

Note: Install the side brush until it clicks into place.

3. Connect to a power outlet and start charging

Place the base on level ground against the wall and connect it to a power outlet. Place the robot onto the base to charge. The robot will turn on automatically and begin charging. It is recommended to fully charge your robot before first-time use.

Place the base within the best Wi-Fi range

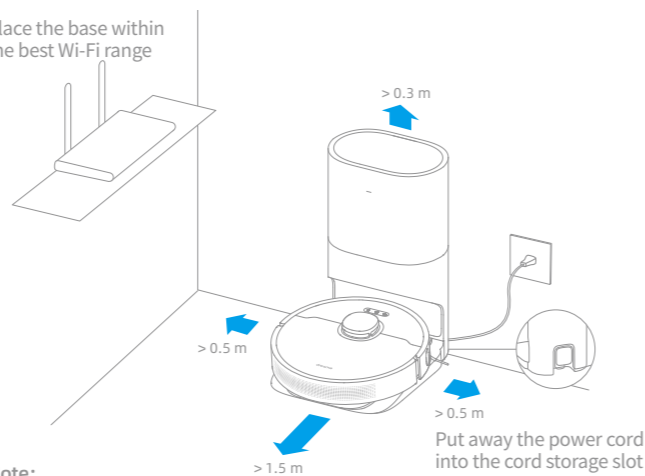

Note:

- Keep the immediate area 1.5m in front of the base and 0.5m to its both sides clear of objects.
- Make sure that no objects might block the signaling area.

About the Auto-Empty Base

It is recommended that the robot set out from the base before cleaning. This ensures that the robot returns to base smoothly. Do not move the base while the robot is cleaning.

After the robot completes the cleaning task and automatically returns to the base, the base will start auto-empty. More settings can be operated on the APP.

Connecting with Mi Home/Xiaomi Home App

This product works with the Mi Home/Xiaomi Home app.* Use the Mi Home/Xiaomi Home app to control your device and interact with other smart devices.

1. Download the Mi Home/Xiaomi Home App

Scan the QR code to download and install the app. You will be directed to the connection setup page if the app has been installed already. Alternatively, search "Mi Home/Xiaomi Home" in the app store to download and install it.



2. Add Device



Open the Mi Home/Xiaomi Home app, and tap "+" in the upper right. Then tap "🔗" in the top right corner, scan the QR code, add "Dreame Bot Z10 Pro", and follow the prompts to finish the connection.



Note:

- Only 2.4GHz Wi-Fi is supported.
- The version of the app might have been updated, please follow the instructions based on the latest app version.

3. Reset Wi-Fi

Simultaneously press and hold the buttons  and  until you hear a voice say, "Waiting for the network configuration." Once the Wi-Fi indicator is blinking slowly, the Wi-Fi has been successfully reset.

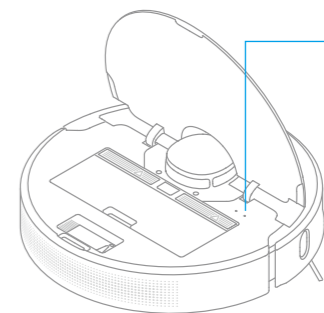

Wi-Fi Indicator

- Blinking slowly: To be connected
- Blinking quickly: Connecting
- On: Wi-Fi connected

Note: If your robot cannot connect to the app successfully, reset the Wi-Fi and add the device again.

Clean the Dust Bin

1. Open the robot cover, then press the dust bin clip to remove the dust bin.

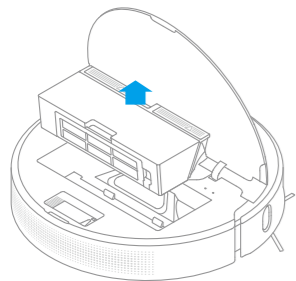

4. Clean the dust intake.

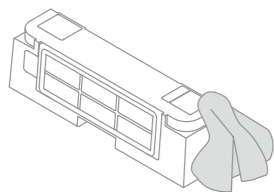

2. Open the bin cover and empty the bin as shown in the diagram.

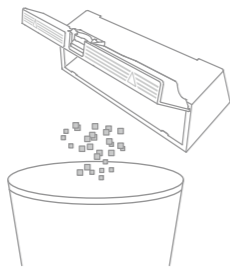

5. Rinse the dust bin and filter with water until they are clean. Thoroughly dry the filter before re-installing.

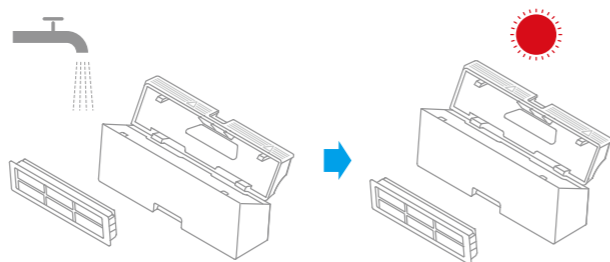

Note:

- Rinse the filter with clean water only. Do not use detergent.
- Before using, keep it in a well-ventilated or cool place.

3. Remove the filter and tap its basket gently.

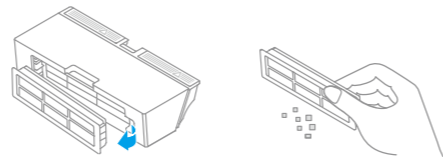

Note: Do not attempt to clean the filter with a brush or finger.

Clean the Mopping Module

1. Press the two release clips on the side of the water tank, remove the mopping module, and pull the mop pad off the mopping module.

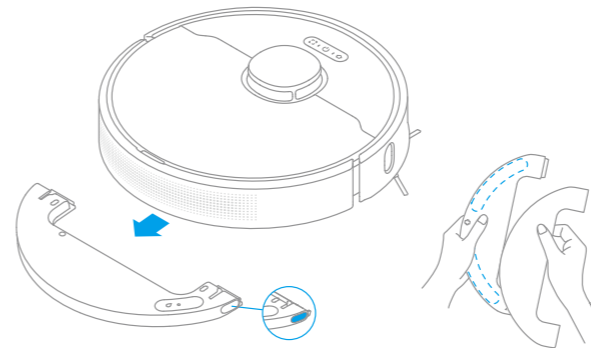

2. Pour out the water in the tank. Clean with only water and leave out to air dry before re-installing.

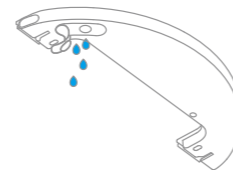

Note: Do not expose the tank to the sun directly.

3. Clean the mop pad with water only and leave to air dry before re-installing.

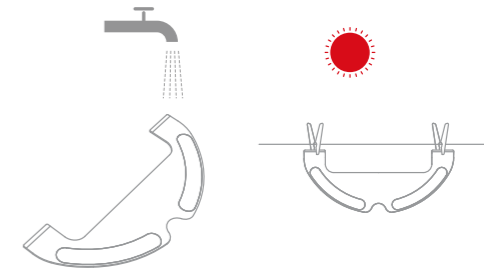

Note:

- Remove the pad from the mopping module before cleaning it, and make sure dirty water does not flow back into the water outlet to avoid clogging.
- For optimal performance, it is recommended to replace the mop pad every 3-6 months.

4. If slow water flow occurs, or the volume is not well-distributed, clean the air hole in the cover of the water tank.



Clean the Main Brush

Press the brush guard clips inwards to remove the brush guard and lift the brush out of the robot.

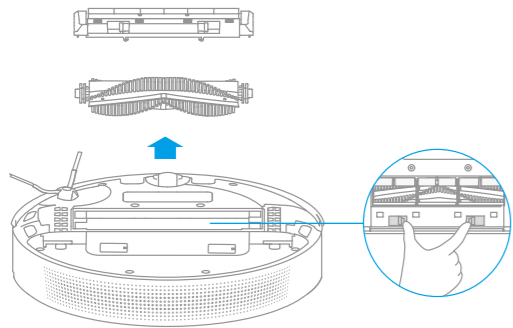

Pull out the brush covers as shown in the diagram. Use the included cleaning tool to remove any hairs tangled in the brush.

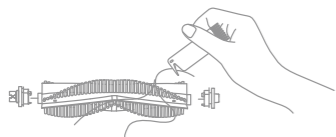

Note: When there is hair tightly tangled in the main brush, do not pull out the hair excessively to avoid damaging the main brush.

Clean the Side Brush

Pull out the side brushes and use the cleaning tool to remove any hair tangled on the brush.



Clean the Main Wheel/Omnidirectional Wheel

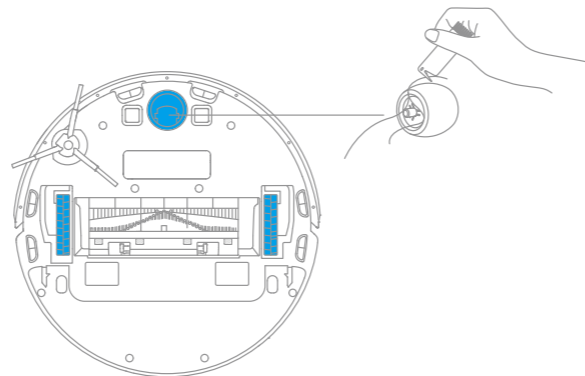

Note: Use a tool such as a small screwdriver to separate axle and tire.

Note: Wet cloths can damage sensitive elements within the robot and base. Please use dry rags for cleaning.

Clean the LDS Laser Sensor/Edge Sensor

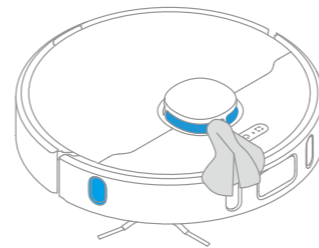

Clean the Cliff Sensor

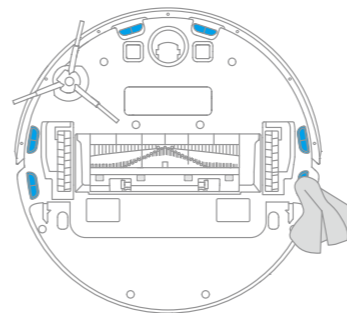

Clean the High Precision 3D

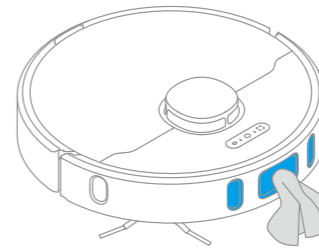

Clean the Charging Contact

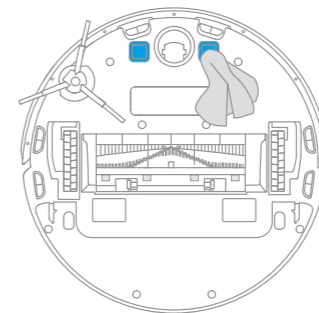

Clean the Charging Contacts and Dust Intake

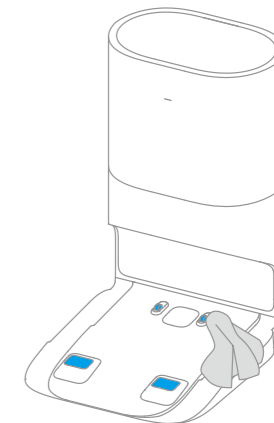

Replace the Dust Collection Bag

According to the status indicator (blinking orange) and app prompts, replace it with a new one when the dust collection bag is full. It is recommended to replace the bag every 6-8 weeks.

1. Discard the dust collection bag

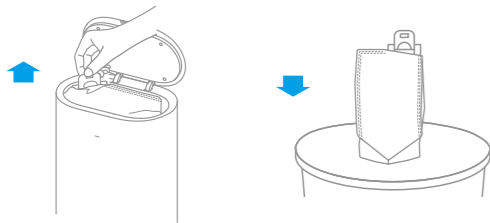

Note: When taking out the dust collection bag, close the dust bag handle to avoid dust leaking out.

2. Clean the filter

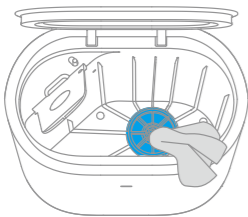

Note:

- Install the filter in place after cleaning to prevent dust from falling into the air duct.
- Rinse the filter with water until it is clean. Thoroughly dry the filter before re-installing.

3. Install a new dust collection bag

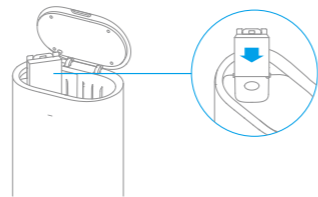

4. Close the upper cover of auto-empty base

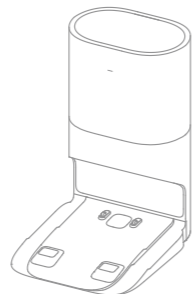

Note: Do not close the base forcibly, if the upper cover of base cannot be closed and the dust collection bag is not installed.

Clean the Air Duct

If the air duct is blocked, please clean it according to the following steps.

1. Unscrew mounting screws on the air duct cover and remove the cover plate.

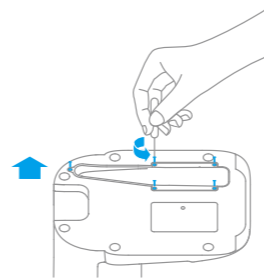

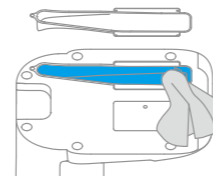

2. Check whether the air duct is blocked by foreign objects. If any, clean them.

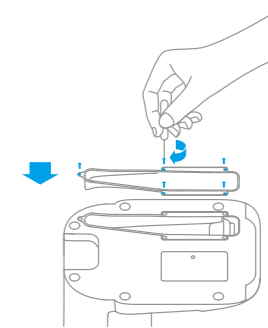

3. Reinstall the air duct cover as shown in the diagram.



Robot Restarting

If the robot stops responding or cannot be turned off, press and hold down the button  for 10 seconds to forcefully turn it off. Then press and hold the button  for 3 seconds to turn the robot on.

Battery

The robot contains a high-performance lithium-ion battery pack. Please ensure that it remains well-charged for daily use to maintain optimal battery performance. If the robot is not used for an extended period of time, turn it off and put it away. To prevent damage from over-discharging, the robot should be recharged at least once every three months.

The following table lists possible causes and solutions in terms of different light status. For more support, please refer to the section "FAQ" in this manual.

Light Status	Possible Cause	Solution
Off	No power supply	Check and ensure that the power supply for the base is normal.
	The robot in the DND period The robot with full charge in sleep mode	/
White	The robot not on the base	/
Breathing White	The robot is charging	/
Blinking Orange	Error	Check whether a dust collection bag is installed. If not, install one. Check whether the dust collection bag is installed in place.
		Check whether the upper cover is closed. If not, close the upper cover tightly.
		Check whether the bag is full. If so, replace it. Remove debris around the dust intake of the robot and base.
		Unplug the power cord of base, and check whether there are any foreign objects that block the air duct cover. If any, clean them. Check whether the special dust bin is used.
		Check whether the dust bin of robot is installed. For other errors, contact qualified technicians or after-sales service.

Problem Type	Solution
Robot does not turn on	The battery level is low. Recharge the robot on the base, then try it again. The ambient temperature is too low (below 0° C) or too high (above 40° C). The operating temperature of the robot is 0° C to 40° C.
Robot cannot recharge	The base is not receiving power. Please confirm that both ends of the power cord are plugged in correctly. Poor contact. Clean charging contacts of the base and robot.
Robot cannot return to the base	There are too many obstructions around the base. Place the base in a more open area. Please clean the signaling area of the base. Moving the robot may cause it to re-position itself or re-map its surroundings. If the robot is too far from the base, it might not be able to automatically return on its own, in which case you need to manually place the robot onto the base.
Robot is malfunctioning	Turn off the robot and then reactivate it.
Robot is making a strange noise	A foreign object may be caught in the main brush, side brush, or one of the main wheels. Stop the robot and remove any debris.
Robot no longer cleans efficiently or leaves dust behind	The dust bin is full. Please clean the dust bin and dust intake. The filter is blocked. Please clean it. A foreign object is caught in the main brush. Please clean it.

Problem Type	Solution
Robot cannot connect to Wi-Fi	<p>There is something wrong with the Wi-Fi connection. Reset the Wi-Fi and download the latest version of the Mi Home/ Xiaomi Home app, then try reconnecting.</p> <p>Location permission is not open. Please ensure the location permission on the Mi Home/Xiaomi Home app is enabled.</p> <p>Wi-Fi signal is weak. Make sure the robot is in an area with good Wi-Fi coverage.</p> <p>5GHz Wi-Fi is not supported. Please ensure your robot connects to 2.4GHz Wi-Fi.</p> <p>The username or password of Wi-Fi is incorrect. Please enter the correct username and password.</p>
Robot does not perform scheduled cleaning	The robot has low battery. Scheduled cleaning will not start unless the robot has been recharged in time.
Does leaving the robot on the base consume power if it is already fully charged?	Leaving the robot on the base after it's fully charged consumes very little electricity and helps maintain optimal battery performance.
No water comes out of the mopping module, or only a little bit comes out	<p>Check whether there is water inside the water tank.</p> <p>Clean the mop if it becomes dirty.</p> <p>Make sure the mop pad is installed correctly according to the user manual.</p> <p>Clean the blowhole on the top of the water tank.</p>
Robot doesn't resume cleaning after charging	<p>Make sure the robot is not set to Do Not Disturb mode (DND), which will prevent it from resuming cleaning.</p> <p>The robot does not resume cleaning when it is manually recharged or placed onto the base.</p>

Problem Type	Solution
Robot returns to the base without performing auto-empty tasks	If you manually press the dock button to recharge the robot, or move it back to the base, and if the cleaning area is less than 3 square meters, the robot will not perform tasks. DND mode prevents prevents the robot from performing auto-empty tasks.
The dust collection bag is full	Check whether the dust collection bag is full. If so, replace it with a new one. It is recommended to replace the bag every 6-8 weeks. If not, check whether the dust intake or air duct at the bottom of the base is blocked. Remove any blockage before use.
The auto-empty duration can be unacceptably long sometimes	When the robot has been performing auto-empty tasks for a period of time, or when the air duct does not function smoothly, the auto-empty duration will be extended to prevent blockage.
The upper cover of base fails to be closed	Check whether a dust collection bag is installed. If not, install one.

Robot

Model	RLSD5
Battery	5200mAh (Battery Nominal Capacity)
Wireless Connectivity	Wi-Fi IEEE 802.11b/g/n 2.4 GHz
Charging Time	Approx. 6 hours
Rated Voltage	14.4 V $\overline{\text{---}}$
Rated Power	46 W
Operation Frequency	2400-2483.5 MHz
Maximum Output Power	< 20 dBm

Auto-Empty Base

Model	RCS2
Rated Input	220-240 V~ 50-60 Hz
Rated Output	19.8 V $\overline{\text{---}}$ 1 A
Rated Power	600 W

Under normal use of condition, this equipment should be kept a separation distance of at least 20cm between the antenna and the body of the user.

WEEE Information



All products bearing this symbol are waste electrical and electronic equipment (WEEE as in directive 2012/19/EU) which should not be mixed with unsorted household waste. Instead, you should protect human health and the environment by handing over your waste equipment to a designated collection point for the recycling of waste electrical and electronic equipment, appointed by the government or local authorities. Correct disposal and recycling will help prevent potential negative consequences to the environment and human health. Please contact the installer or local authorities for more information about the location as well as terms and conditions of such collection points.