

# T16 Pro Heat-R

Wet and Dry Vacuum

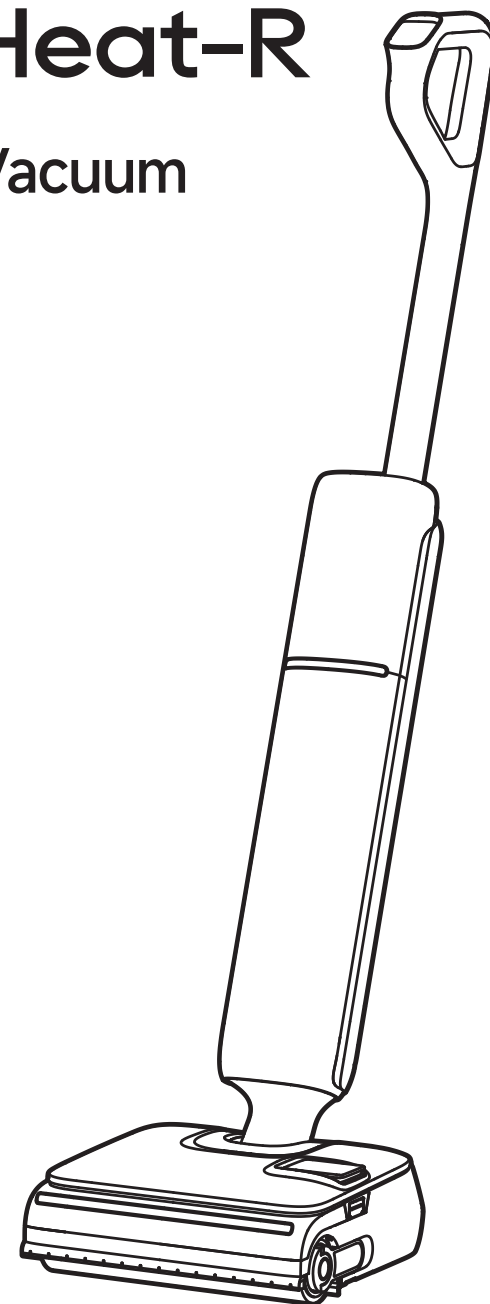

## User Manual

The illustrations in this manual are for reference only.  
Please refer to the actual product.

**DREAME**



Website: <https://global.dreame.tech.com>  
Manufactured by: Dreame Trading (Tianjin) Co.,Ltd.  
Made in China

EU-A00



# THANK YOU

## FOR PURCHASING THIS DREAME WET AND DRY VACUUM

---

The high-quality product is engineered for optimal performance.

If you have any questions on the product,  
please contact us: <https://global.dreametech.com/pages/contact-us>

---

## Contents

<b>EN</b>	User Manual	01
<b>DE</b>	Benutzerhandbuch	19
<b>FR</b>	Mode d'emploi	37
<b>IT</b>	Manuale d'uso	55
<b>ES</b>	Manual de usuario	73
<b>NL</b>	Gebruikershandleiding	91
<b>PT</b>	Manual do utilizador	109



Please scan the QR code to get the User Manual in multiple languages.

# Important Safety Instructions

To avoid electric shock, fire or injury caused by improper use of the appliance, please read the user manual carefully before using the appliance and keep it for future reference.

## Usage Restrictions

- This appliance is not intended for use by persons (including children) with reduced physical, sensory or mental capabilities, or lack of experience and knowledge, unless they have been given supervision or instruction concerning the use of the appliance by a person responsible for their safety. Children should be supervised to ensure that they do not play with the appliance.
- This appliance should not be used by children younger than 8 years old nor persons with physical, sensory, intellectual deficiencies, or limited experience or knowledge without the supervision of a parent or guardian to ensure safe operation and to avoid any risks. Cleaning and maintenance shall not be performed by children without supervision
- This appliance contains batteries that are only replaceable by skilled persons.
- Do not install, charge or use the appliance in the bathrooms or around the pools.
- The appliances with rotating brushes, a hazard may occur if the appliance runs over the supply cord.
- The plug must be removed from the socket-outlet before cleaning or maintaining the appliance.
- Under normal use of condition, this equipment should be kept have a separation distance of at least 20cm between the antenna and the body of the user.
- If the supply cord is damaged, it must be replaced by the manufacturer, its service agent or similarly qualified persons in order to avoid a hazard.
- The appliance is only to be used with the power supply unit provided with the appliance.
- Plastic film can be dangerous. To avoid the danger of suffocation, keep it away from children.
- Use indoors only, on non-carpeted floor surfaces such as vinyl, tile, sealed wood, etc. Be careful not to run over loose objects or the edges of area rugs. Stalling the brush may result in premature belt failure.
- Use only as described in this user guide. Use only manufacturer's recommended attachments.
- Do not expose the appliance to fire or excessive temperature. Exposure to fire or excessive temperature may cause an explosion.
- Do not use in extremely hot or cold environments (below 5°C/41°F or above 40°C/104°F). Please charge the appliance in temperature above 5°C/41°F and below 40°C/104°F.
- Do not immerse the appliance in liquid.
- Do not use to pick up flammable or combustible liquids, such as gasoline. Do not use in areas where flammable or combustible liquids may be present.
- Do not put any object into openings. Do not use the appliance when any opening is blocked. Keep free of dust, lint, hair, and anything that may inhibit air flow.
- Do not pick up toxic materials (chlorine bleach, ammonia, drain cleaner, etc.). Do not pick up hard or sharp objects such as glass, nails, screws, coins, etc.
- Do not use the appliance in an enclosed space filled with vapor given off by oil-based paint, paint thinner, some moth-proofing substances, flammable dust, or other explosive or toxic vapour. Do not pick up anything that is burning or smoking, such as cigarettes, matches or hot ashes.
- Do not use the appliance without filters in place.
- Keep hair, loose clothing, fingers, and all parts of the body away from openings and moving parts of the appliance and its accessories.
- Keep ground cables away from the appliance when using it. A hazard may occur if the appliance runs over a supply cord.
- Use extra care when cleaning on stairs.
- Do not install, charge or use the appliance in the bathrooms or around the pools.
- Prevent unintentional starting. Ensure the switch is in the OFF-position before picking up or carrying the appliance. Carrying the appliance with your finger on the switch or turning on the appliance may result in an accident.

# Important Safety Instructions





- Ensure that the appliance is placed on a horizontal surface. Do not use the appliance at the same position if the appliance is equipped with a brush roller and the handle is not completely upright. Do not store the appliance in a place where it may freeze.
- The plug must be removed from the socket-outlet before cleaning or maintaining the appliance. And ensure the appliance is turned off to prevent injury from the rotating brush.
- If the appliance will not be used for an extended period, unplug the power cord and store it in a dry, dust-free, and insect-proof environment.
- Do not operate the appliance without all accessories properly installed.
- Do not use an appliance that is damaged or modified. A damaged or modified appliance may exhibit unpredictable behavior resulting in fire, explosion, or risk of injury.
- Do not modify or attempt to repair the appliance except as indicated in the instructions for use and care.
- Do not use the appliance with a damaged attachment (e.g.: charging base.). If the appliance or attachment has been dropped, damaged, left outdoors, dropped into water, or is not working as it should, never attempt to operate it. Please have it repaired at an authorized service center.
- Have servicing performed by a qualified repair person using only identical replacement parts. This will ensure that the safety of the appliance is maintained.
- Make sure the appliance is turned off when being transported and kept in its original packaging if possible.
- Please use this product in accordance with the instructions in the User Manual. Users are responsible for any loss or damage that arises from improper use of this product.
- Only clean water and the officially-approved cleaning solution can be added to the clean water tank. Do not add any other liquid such as alcohol or disinfectant. The ratio of the cleaning solution to clean water can be checked on the cleaning solution bottle. Keep the cleaning solution out of reach of children.

## Battery and Charging

- For the purpose of recharging the appliance, only use the charging base provided with this appliance. Use only with HCBBU charging base.
- This appliance contains batteries that are only replaceable by skilled persons.
- Follow all charging instructions and do not charge the appliance outside of the temperature range specified in the battery as doing so increases the risk of fire.
- Charging base is equipped with drying function and only suitable for drying this appliance's brush.
- Keep the charging base cable away from heated surfaces. Do not handle the charging base plug or appliance with wet hands. To unplug, grasp the charging base plug, rather than the cable.
- Do not pull or carry charging base by cable, use cable as a handle, close door on cable, or pull cable around sharp edges or corners.
- Keep batteries out of the reach of children. Never put batteries in mouth. If swallowed, contact your physician or local poison control.
- The charging base is capable of charging the 6-cell 4000 mAh battery pack. This charging base should not be used to charge non-rechargeable batteries. Failing to do so may cause the lithium-ion battery to catch fire.
- Do not improperly dispose of old batteries. Unneeded batteries should be discarded at an appropriate recycling facility.

# Important Safety Instructions

## Symbols

-  Class II equipment
-  Time-lag miniature fuse-link where T 3.15A is the symbol for the time/current characteristic
-  For indoor use only
-  Read operator's manual
-  WEEE Information

We, Dreame Trading (Tianjin) Co., Ltd., hereby declares that this equipment is in compliance with the applicable Directives, European Norms, and amendments. The full text of the EU declaration of conformity is available at the following internet address: <https://global.dreame.tech.com>

For detailed e-manual, please go to <https://global.dreame.tech.com/pages/user-manuals-and-faqs>

# Product Overview

## Packing List

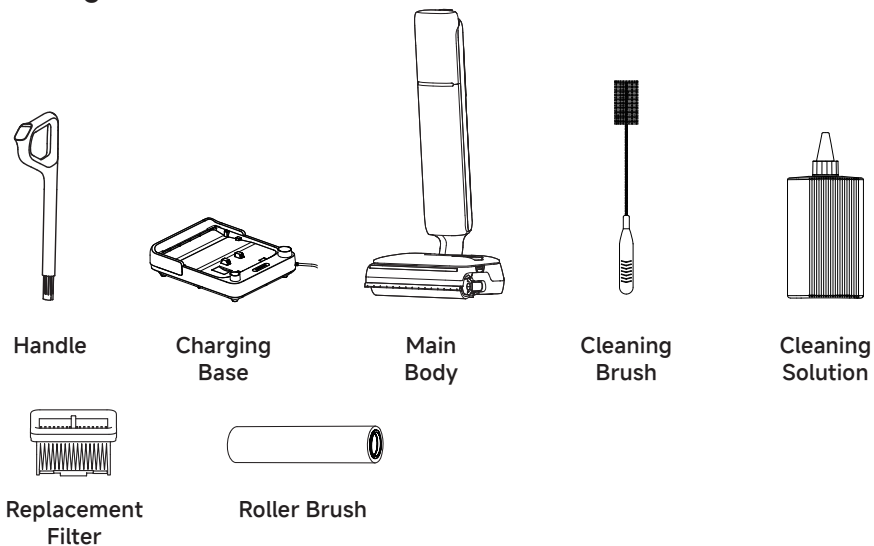

# Product Overview

## Vacuum

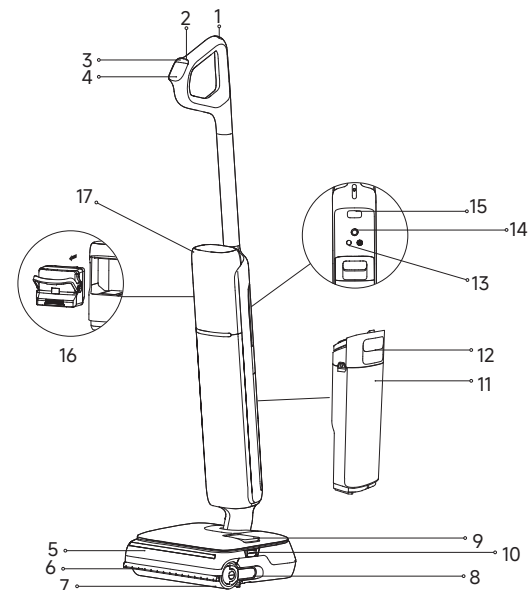

- |                        |                           |   |
|------------------------|---------------------------|---|
| 1 Self-Cleaning Button | 7 Roller Brush            | 13 Voice Prompt/Wi-Fi Button                              |
| 2 Power Switch         | 8 Roller Brush Handle     | • Press briefly to turn on voice prompt or adjust volume. |
| 3 Mode Switch          | 9 Clean Water Tank        | • Press and hold to start/stop Wi-Fi setup.               |
| 4 Display Screen       | 10 Tank Release Buttons   | • Set languages via the APP.                              |
| 5 Roller Brush Cover   | 11 Used Water Tank        | 14 Omnidirectional Wheel                                  |
| 6 Lifting Robotic Arm  | 12 Used Water Tank Handle | 15 Motor Release Button                                   |
|                        |                           | 16 Battery Pack   |
|                        |                           | 17 Motor  |

## Charging Base

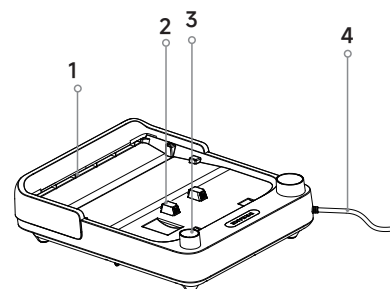

- 1. Air-Drying Outlet
- 2. Charging Contacts
- 3. Accessory Storage Slot
- 4. Power Cord

# Installation & Charging

Fully charge the appliance before first use.

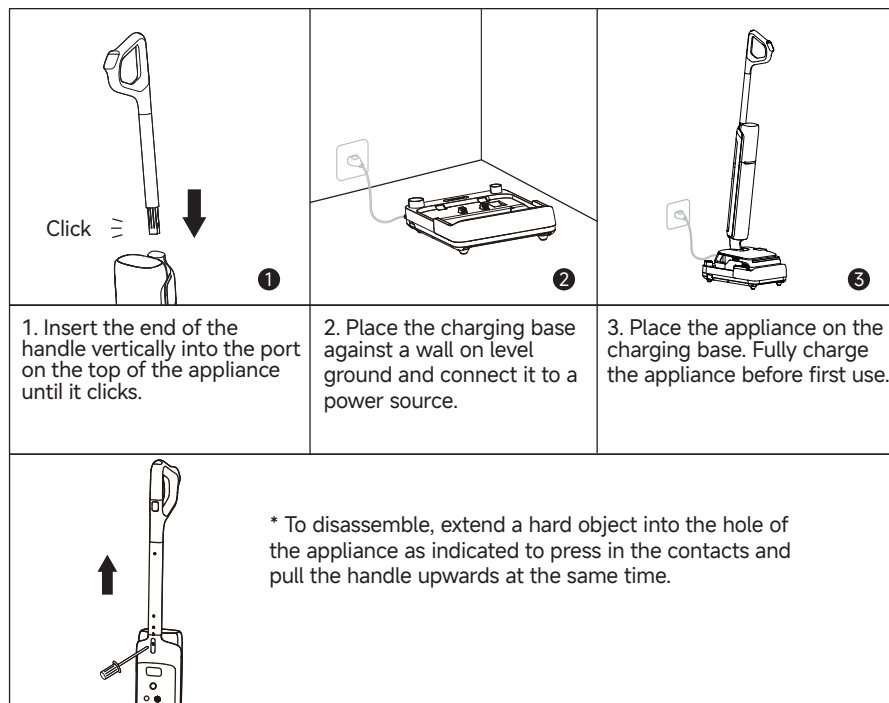

## Note:

- If there is no operation within 10 minutes of being fully charged, the appliance will enter sleep mode. Please restart the appliance if you need to use it.
- To extend the battery life time, the battery keeps cooling down automatically after you have used the appliance for a long time.



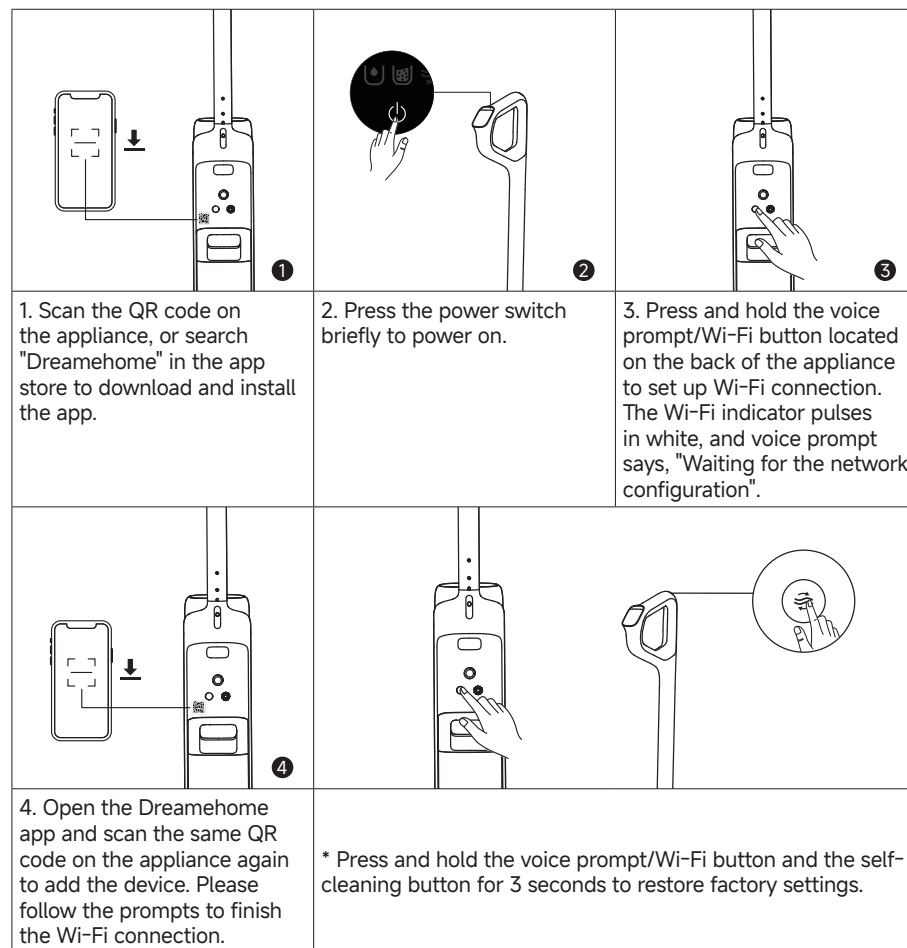



# Connecting with Dreamehome App

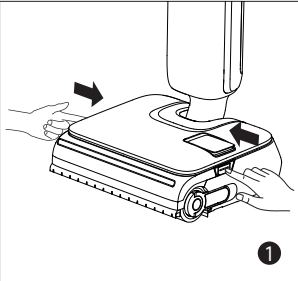
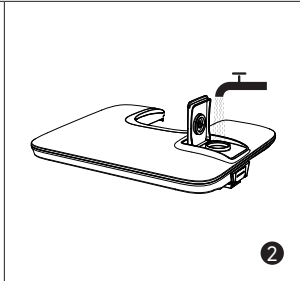
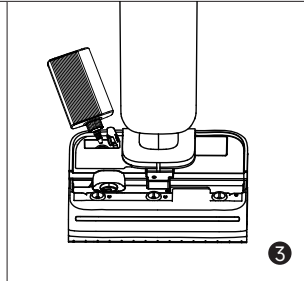
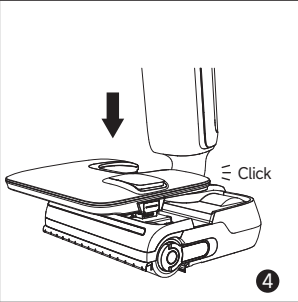
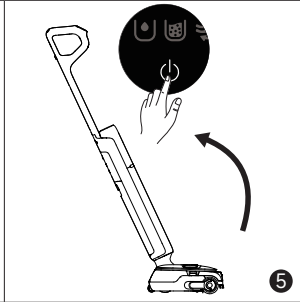
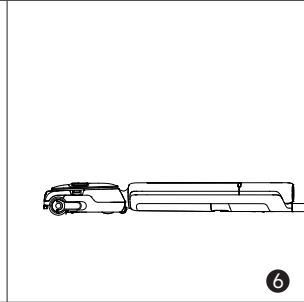

## Note:

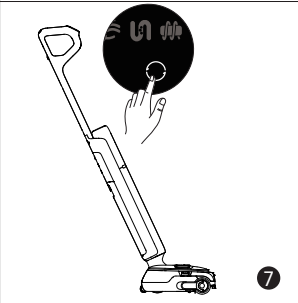
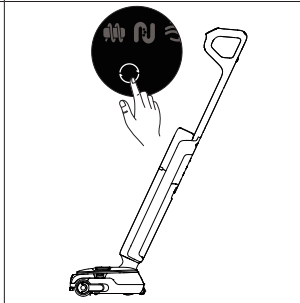
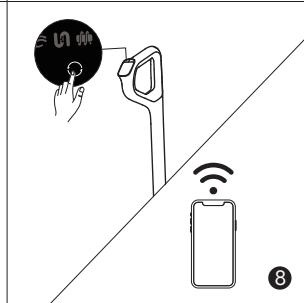
- Only 2.4 GHz Wi-Fi is supported.
- Due to upgrades in the app software, the actual operations may differ from the directions in this manual. Please follow the instructions based on the current app version.
- The appliance will exit the network connection if there is no operation for 10 minutes, or if the network connection fails. To reset Wi-Fi, please repeat the steps above and complete the connection according to the prompts in the app.
- After Wi-Fi setup is complete, press and hold the voice prompt/Wi-Fi button to disable the network connection. Press and hold again to reconnect to Wi-Fi.

## Starting Cleaning

		
<p>1. Press the Tank Release Buttons to remove the tank.</p>	<p>2. Open the clean water inlet, fill with water, and close it tightly.</p>	<p>3. Open the cleaning solution inlet, add solution, and close it tightly.</p>
		
<p>4. Reinstall the clean water tank until it clicks.</p>	<p>5. Gently step on the floor brush and recline the appliance backwards. Briefly press the power switch  button to start/stop operating.</p>	<p>6. The appliance can lie flat at a 180-degree angle for easy cleaning under low-profile furniture.</p>
		
<p>7. Briefly press the mode switch  to switch modes according to your needs.</p>	<p>8. Discharging/Standby status: Press and hold the  button for 3 seconds to turn the lifting robotic arm on or off.</p>	<p>9. Charging status: Press and hold the  button for 3 seconds to turn the automatically adjusts the cleaning solution ratio on or off.</p>

Note: The lifting robotic arm and cleaning solution ratio automatic adjustment are on by default. To adjust or disable them, go to the app settings.

## Starting Cleaning

Note:

- Do not vacuum any foamy liquids.
- The appliance is suitable for cleaning floors, marble, tiles and other hard surfaces.
- When the appliance is in operation, do not lift it off the ground, move it or tilt it. Otherwise, the used water may flow into the motor.
- Do not add any liquids other than the officially-approved cleaner. The cleaner can be available on the official online store. Refer to the cleaning solution label for specific usage instructions.
- For subsequent use, the appliance will automatically enter the last used mode upon startup.

## Display Screen



### Smart Mode

The appliance will detect the stain level and intelligently adjust the suction power and water flow accordingly.



### Hot Water Mode

Suitable for cleaning moderate stains, with the water temperature gradually rising to the hot water level.



### Turbo Mode

Maximum suction power and increased water flow for stubborn stains on hard floors.



### Suction Mode

Suck up a large amount of water from the floor.



### Self-Cleaning Mode



### Drying Mode



### Dust Concentration Indicator / Self-Cleaning & Drying Progress Indicator / Charging Indicator

The color of the indicator changes with the amount of dirt in real time.



### Custom Mode

Suction power, water volume, etc. can be adjusted within the APP. The main body will start working according to the settings in the APP.



### Cleaning Solution Status Indicator Solid On

Diluting function enabled



### Insufficient water in the clean water tank



### The used water tank is full



Max capacity-Upright



Max capacity-Flat



### Blocked tube



### Roller brush stuck



### Appliance malfunction



### Battery Indicator



- Solid Green: 50% < Battery level ≤ 100%
- Red: Battery level ≤ 20%

\*Battery Indicator color cycles from green to yellow, orange, and red as charge decreases. Recharge when red.

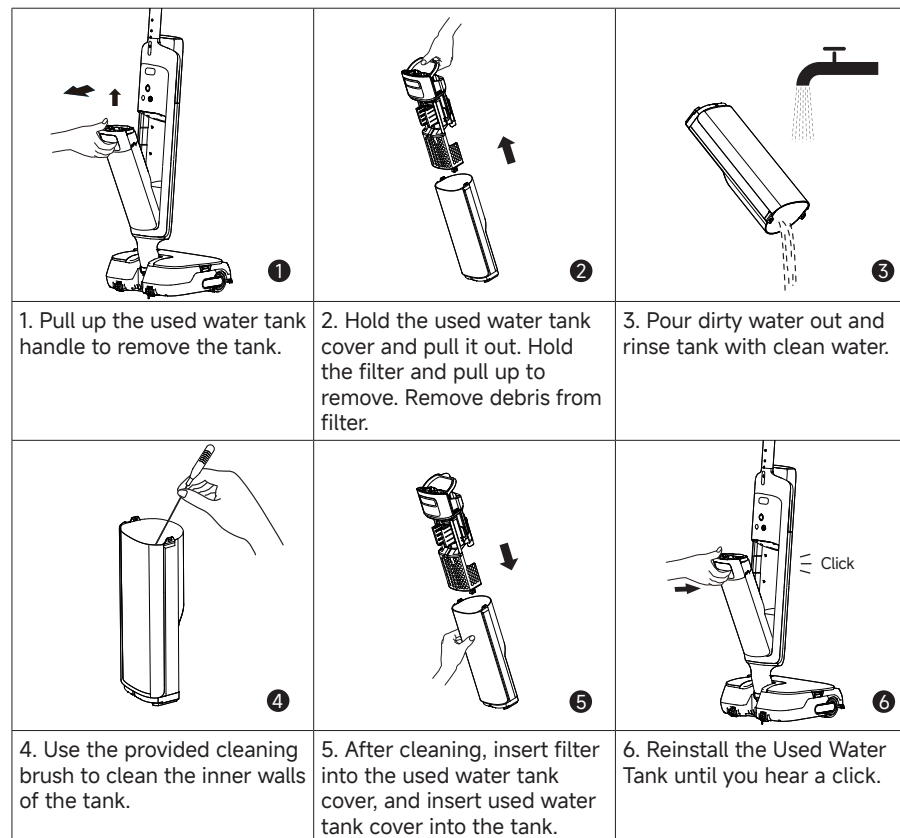
## Emptying the Used Water Tank

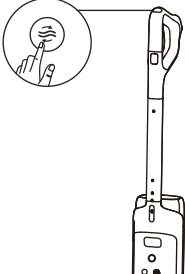
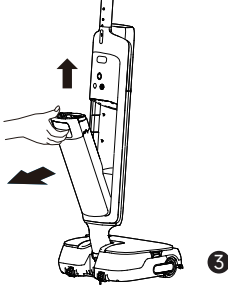

## Self-Cleaning & Drying Mode



		
<p>1. Place the appliance back onto the base. Ensure that the water in the clean water tank is sufficient for self-cleaning.</p>	<p>2. Briefly press the self-cleaning button on the top of the handle to start/stop self-cleaning (Battery level <math>\geq 20\%</math>).</p>	<p>3. After self-cleaning is complete, the  will light up. Empty the used water tank promptly.</p>

	<p>To switch from 30-minute Drying (default) to 5-minute Fast Drying, press the button again within 3 seconds.</p>
	<p>Press and hold for 3 seconds to enter independent 30-minute drying mode.</p>
	<p>In drying mode, press briefly to exit drying mode.</p>

## Care & Maintenance

### Tips:

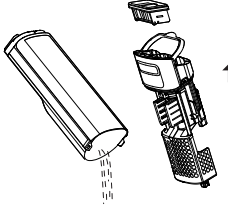

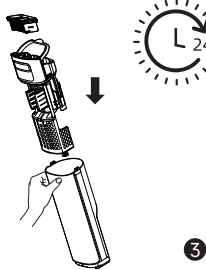
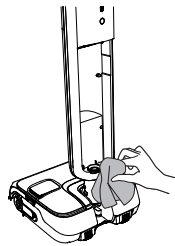
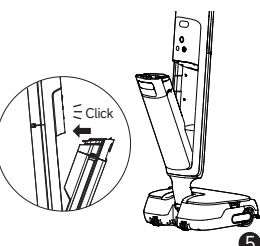
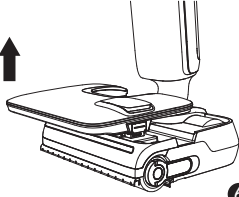
- Turn off the appliance before maintenance. Do not touch the power switch.
- Replace parts if needed. The parts must be replaced by those available from the manufacturer or its service agent.
- If the appliance will not be used for an extended period of time, fully charge it, then turn it off and store it in a cool, dry place. Recharge the appliance at least once every 3 months to avoid over-discharging the battery.

		
<p>1. Pour dirty water out, remove the filter, and rinse the tank and tank cover with clean water.</p>	<p>2. Gently knock off the floating dust on the filter surface. When the filter is dirty and needs washing, rinse it with water.</p>	<p>3. After fully drying the filter, reinstall it into the used water tank cover. Insert used water tank cover into the tank.</p>
		
<p>4. Gently wipe the tube and dirt sensor with a wet cloth before use. Do not rinse the tube.</p>	<p>5. Insert bottom of tank into main body. Tilt tank towards main body until it clicks.</p>	<p>6. Remove the clean water tank.</p>

### Tips:

- When the battery is low, the 5-minute drying mode will switch to a combined 30-minute charge-and-dry cycle after self-cleaning.

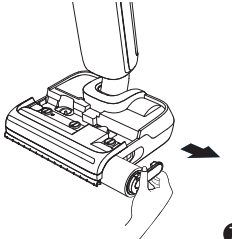
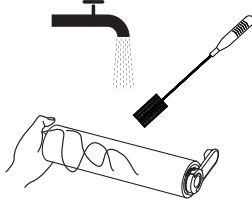
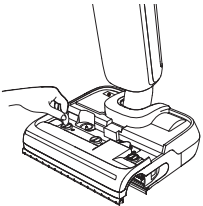
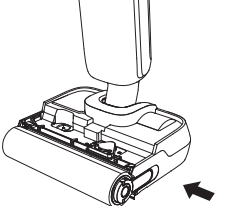
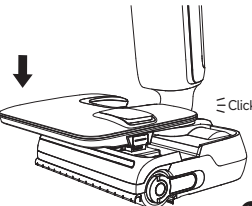
## Care & Maintenance

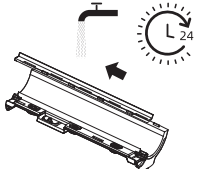
 <p>7</p>	 <p>8</p>	 <p>9</p>
<p>7. Pull out the brush handle and remove the brush.</p>	<p>8. Remove hair or debris tangled on the roller brush with the provided cleaning brush. Rinse the roller brush with clean water.</p>	<p>9. After removing the clean water tank, use a coin to turn the locking knobs on the roller brush cover and detach the cover.</p>
 <p>10</p>	 <p>11</p>	 <p>12</p>
<p>10. After fully drying the roller brush, hold the roller brush handle and reinstall it.</p>	<p>11. Reinstall the clean water tank until you hear a click.</p>	<p>* Remove the roller brush handle to replace it with a new roller brush, and press it firmly into place.</p>
 <p>12</p>		
<p>12. Flip the roller brush cover, pull out the lifting robotic arm, and push the scraper to the left to remove it. Rinse the scraper with clean water. Once fully dry, align it with the slot and push it to the right to reinstall.</p>		

## Care & Maintenance

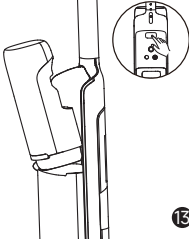
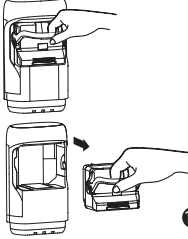
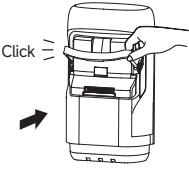
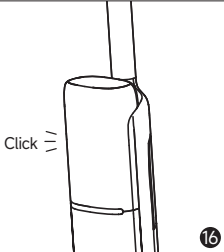
 <p>13</p>	 <p>14</p>	 <p>15</p>
<p>13. To replace the battery pack, press the motor release button and slide it out.</p>	<p>14. Pull down the battery pack handle to remove the pack.</p>	<p>15. Insert a new battery pack into the motor and put the handle back until it clicks.</p>
 <p>16</p>		
<p>16. Put the motor back until it clicks.</p>		

### Note:

- Replacing the filter every 3 to 6 months is recommended.
- Clean as needed. Replacing the roller brush every 3 to 6 months is recommended.

# Troubleshooting

If an error occurs, the appliance will stop working. Please refer to the following table for troubleshooting. If the problem persists, please contact customer service.

Error	Possible Cause	Solution
The appliance does not work.	The appliance is out of battery or its battery level is low.	Fully charge its battery before use.
	The appliance is in the upright position.	Recline the appliance backwards.
	Blockage activated overheat protection mode.	Clear the blockage and wait until the temperature returns normal.
	The Used Water Tank is full.	Empty the Used Water Tank.
The handle, roller brush, or Used Water Tank is not properly installed.	The handle, roller brush, or Used Water Tank is not properly installed.	Ensure the handle, roller brush, or Used Water Tank are all properly in place.
The appliance charges slowly.	The temperature of the battery is too low or too high.	Wait until the battery's temperature returns normal.
The suction power of the appliance is weak.	The filter is clogged.	Cleaning the filter.
	The suction inlet or tube is blocked by a foreign object.	Clean the tube and the suction inlet.
The motor is making a strange noise.	There is too much used water in the Used Water Tank.	Empty the Used Water Tank.
	The suction inlet is blocked.	Clear any blockage in the suction inlet.
The display screen does not light up while charging.	The charging base cable is not plugged into the electrical outlet.	Make sure the charging base cable is plugged in.
	The appliance is not placed onto the charging base properly.	Make sure the appliance is placed onto the charging base properly.
No water is coming out of the appliance.	The Clean Water Tank is not properly installed in place, or the water in the Clean Water Tank is insufficient.	Reinstall or fill the Clean Water Tank.
	It takes 30 seconds to dampen the roller brush.	Turn on the appliance and check again in 30 seconds.





# Troubleshooting

The vent leaks water	A collision or a sharp pull causes water to enter the motor.	Move the appliance gently back and forth while it is turned on.
	The filter is not completely dry after being cleaned.	Dry the filter completely before use.
Self-cleaning fails	The roller brush may be jammed by large debris.	Open the roller brush cover to check and clean the roller brush.
	The appliance is not placed onto the charging base properly.	Make sure the appliance is being charged before self-cleaning.
	Self-cleaning cannot be enabled if the battery level is lower than 20%.	The self-cleaning function can only be enabled when the appliance is being charged and the battery level is more than 20%.
	The Used Water Tank is not installed in place, or the Used Water Tank is full.	Reinstall or empty the Used Water Tank.
Wi-Fi Connection fails	The Clean Water Tank is not installed in place, or the water in the Clean Water Tank is insufficient.	Reinstall or fill the Clean Water Tank.
Wi-Fi Connection fails	The Wi-Fi network password is incorrect.	Make sure the password used to connect to your Wi-Fi network is correct.
	The appliance does not support a 5 GHz Wi-Fi connection.	Make sure the robot is connected to a 2.4 GHz Wi-Fi connection.
	The Wi-Fi signal is weak.	Make sure the robot is in an area with good Wi-Fi coverage.
	The appliance may not be ready to be configured.	Please exit and re-enter the app, and then try again as instructed.

For additional services, please contact us via <https://global.dreametech.com/pages/contact-us>  
Website: <https://global.dreametech.com>

## Error Prompts and Solutions

If the appliance is not working properly, the screen display will show an error message. Please refer to the troubleshooting table to find your solution.

Error Icon	Possible Cause	Solution
	Insufficient water.	Fill the clean water tank.
	The Used Water Tank is full.	Please clean the used water tank.
	Roller brush stuck.	Clean the roller brush.
	Blocked tube.	Refer to the Care & Maintenance section to clean the tube and dirt sensor.
	Appliance malfunction	Restart the appliance for troubleshooting. If the problem persists, please contact customer service.

## Specifications

Wet and Dry Vacuum Floor Washer			
Model	HHV58A	Charging Time	approx. 4 hours
Rated Voltage	21.6 V ---	Rated Power	420 W
Operation Frequency	2400- 2483.5 MHz	Maximum Output Power	< 20 dBm
Charging Base			
Model	HCBBU	Rated Power Input*	340 W
Rated Input	220-240 V ~ 50- 60 Hz	Rated Output	27 V --- 1.6 A
Motorized Cleaning Head			
Model	HCRS	Rated Voltage	21.6 V ---
Rated Power	60 W		

\* The rated input power is the power value taken from the operating state during the self-cleaning period.

\* Power consumption in standby mode: ≤ 0.5W (within 15 minutes after the vacuum removed from the Charging Base)

\* Power consumption in network standby mode: ≤ 2W (within 15 minutes after the appliance is fully charged)

\* Power consumption in standby mode: ≤ 0.5W (within 15 minutes after the appliance is fully charged)

## Battery Disposal and Removal

The built-in lithium-ion battery contains substances that are hazardous to the environment. Before disposing of the battery, make sure the battery is removed by qualified technicians and discarded at an appropriate recycling facility.

- the battery must be removed from the appliance before it is scrapped;
- the appliance must be disconnected from the supply mains when removing the battery;
- the battery is to be disposed of safely.

### Removal Guide

1. To replace the battery pack, press the motor release button and slide it out.
2. Pull down the battery pack handle to remove the pack.
3. Insert a new battery pack into the motor and put the handle back until it clicks.
4. Put the motor back until it clicks.

### CAUTION:

- Before removing the battery, disconnect the power and run out the battery as much as possible.
- Unneeded batteries should be discarded at an appropriate recycling facility.
- Do not expose to high temperature environment to avoid risks of explosion.
- Under abusive conditions, liquid may be ejected from the battery. If contact occurs, flush with water and seek medical help.

### • Warranty

1. Dreame is liable to the consumer for any lack of conformity in material or workmanship not detectable at the time of the purchase.
2. Warranty period: please refer to the customer service office for more information. If the territory where the consumer is located has different regulations, local regulations prevail.
3. The warranty will not be applicable in the following cases:
  - a) Issues due to carelessness, use, or installation that does not comply with the instructions provided by Dreame.
  - b) Tampering and/or modifications of the product by entities or individuals not expressly authorized by Dreame.
  - c) Damage due to accidental causes and/or negligence on the part of the consumer, with particular reference to external parts.
  - d) Parts subject to wear that do not have manufacturing defects.
  - e) No valid purchasing document (receipt, invoice, or other) is provided to certify the date the product was purchased.
  - f) The model and/or numbers of the product on the purchase certificate is not consistent with the model and/or numbers shown on the product.
4. For more warranty information, please refer to the official Dreame website: <https://global.dreame.tech.com>



### WEEE Information

All products bearing this symbol are waste electrical and electronic equipment (WEEE as in directive 2012/19/EU) which should not be mixed with unsorted household waste. Instead, you should protect human health and the environment by handing over your waste equipment to a designated collection point for the recycling of waste electrical and electronic equipment, appointed by the government or local authorities. Correct disposal and recycling will help prevent potential negative consequences to the environment and human health. Please contact the installer or local authorities for more information about the location as well as terms and conditions of such collection points.

We, Dreame Trading (Tianjin) Co., Ltd., hereby declares that this equipment is in compliance with the applicable Directives, European Norms, and amendments. The full text of the EU declaration of conformity is available at the following internet address: <https://global.dreame.tech.com>

For detailed e-manual, please go to <https://global.dreame.tech.com/pages/user-manuals-and-faqs>